

TOSHIBA

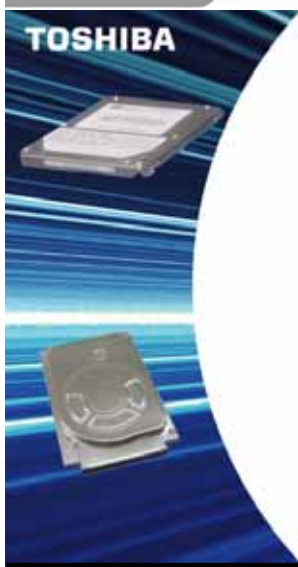

TOSHIBA
Hard Disk Drive Specification
1.8 inch Hard Disk Drive
MK6006GAH/MK4006GAH
/MK3006GAL

Rev. 01

REF 360050398

Toshiba Corporation Digital Media Network Company

Page 1 of 153

© 2003, Copyright TOSHIBA Corporation All Rights Reserved

Revision History

1.8 inch Hard Disk Drive MK6006GAH/MK4006GAH/MK3006GAL Product Specification

Revision	Date	
00	2004-07-01	Initial issue
01	2004-08-10	

SAFETY

The hard disk drive and product specifications contain essential information for the protection of users and others from possible injury and property damage and to ensure correct handling. Please check that you fully understand the definition of the following messages (signs and graphical symbols) before going on to read the text, and always follow the instructions. Please describe requirements in the instruction manual of the product in which the drive is mounted and ensure that users are made thoroughly aware of them.

IMPORTANT MESSAGES

Read this manual and follow its instructions. Signal words such as CAUTION and NOTE, will be followed by important safety information that must be carefully reviewed.

CAUTION

Indicates a potentially hazardous situation which if not avoided, may result in minor injury or property damage.

NOTE

Gives you helpful information.

LIMITATION OF LIABILITY

- Toshiba Corporation shall not be liable for any damage due to the fault or negligence of users, fire, earthquake, or other accident beyond the control of Toshiba Corporation.
- Toshiba Corporation shall not be liable for any incidental or consequential damages including but not limited to change or loss of stored data, loss of profit, or interruption of business, which are caused by use or non-usability of the product.
- Toshiba Corporation shall not be liable for any damage result from failure to comply with the contents in the product specification.
- Toshiba Corporation shall not be liable for any damage based on use of the product in combination with connection devices, software, or other devices provided by Toshiba Corporation with the product.

USAGE RESTRICTIONS

Since the drive is not designed or manufactured to be used for a system including equipment (*1) directly linked with human life, etc., Toshiba Corporation shall not be liable for this type of use.

*1: Equipment directly linked with human life, etc. corresponds to the following.

- Medical equipment such as life support systems, equipment used in operations , etc.

When the drive is to be used for a system including equipment (*2) linked with human safety or having a serious influence on the safe maintenance of public function, etc., special consideration (*3) must be given with regard to operation, maintenance, and management of the system.

*2: A system including equipment linked with human safety or having a serious influence on the safe maintenance of public function, etc. corresponds to the following.

- A main equipment control system used in atomic power plants, a safety protection based system used in atomic facilities, other important safety lines and systems.
- An operation control system for mass transport, an air-traffic control system.

*3: Special consideration means that a safety system (fool proof design, fail safe design, redundancy design, etc.) is established as a result of adequate consultation with Toshiba engineers.

SAFETY

▲ CAUTION

Do not disassemble, remodel or repair.

Disassembly, remodeling or repair may cause injury, failure, or data loss.

Do not drop.

Dropping may cause injury.

Do not touch sharp edges or pins of the drive.

Sharp protrusions etc. may cause injury.

Hold the drive by both sides when carrying it.

SAFETY

Observe the following to prevent failure, malfunction or data loss.

NOTE

Follow the specifications for 7. POWER SUPPLY (page17), 9. ENVIRONMENT (page 22, 23), etc. when using.

Failure to do so may cause damage to the drive.

Observe cautions in 8.3 MOUNTING INSTRUCTION (page18) and 10.6 LOAD / UNLOAD (page27) when handling, setting up, or using the drive.

Take anti-static measures in order to avoid damage to the drive when handling it.

The drive uses parts susceptible to damage due to ESD (electrostatic discharge).

Wear ESD proof wrist strap in accordance with the usage specified when handling a drive that is not in an anti-static protection bag.

There is a certain probability of the drive causing failure including data error or data loss.

Take preventive steps such as backing up data etc. without exception in order to prevent loss etc. in cases where data loss may result in loss or damage.

Please include this in the instruction manual etc. of the system in which this device is used and ensure that users are made thoroughly aware of it.

Inserting or pulling out the drive when the power is turned on may cause damage to the drive.

Exchange the drive etc. after the power of HDD is turned off.

Extreme shock to the drive may cause damage to it, data corruption, etc..

Do not subject the drive to extreme shock such as dropping, upsetting or crashing against other objects.

Do not touch the top cover since application of force to it may cause damage to the drive.

Do not stack the drive on another drive or on other parts etc. or stack them on top of it during storage or transportation.

Shock or weight may cause parts distortion etc..

Labels and the like attached to the drive are also used as a seal for maintenance of its performance.

Do not remove them from the drive.

Attachment of dielectric materials such as metal powder, liquid, etc. to live parts such as printed circuit board patterns or pins etc. may cause damage to the drive.

Avoid attachment of these materials.

Do not place objects which generate magnetic fields such as magnets, speakers, etc. near the drive.

Magnetism may cause damage to the drive or data loss.

TABLE OF CONTENTS

1. SCOPE	11
2. GENERAL DESCRIPTION	11
3. KEY FEATURES	13
4. BASIC SPECIFICATION	15
5. PERFORMANCE	16
6. POWER REQUIREMENTS	17
6.1 SUPPLY VOLTAGE	17
6.2 POWER CONSUMPTION	17
6.3 ENERGY CONSUMPTION EFFICIENCY	17
7. MECHANICAL SPECIFICATIONS	18
7.1 DIMENSION AND WEIGHT	18
7.2 DRIVE ORIENTATION	18
7.3 MOUNTING INSTRUCTIONS	18
7.3.1 <i>Installation</i>	19
8. ENVIRONMENTAL LIMITS	22
8.1 TEMPERATURE AND HUMIDITY	22
8.1.1 <i>Temperature</i>	22
8.1.2 <i>Humidity</i>	22
8.2 VIBRATION	22
8.3 SHOCK	22
8.4 ALTITUDE	23
8.5 ACOUSTICS (SOUND POWER)	23
8.6 SAFETY STANDARDS	24
8.7 EMC ADAPTABILITY	25
8.8 MAGNETIC FIELDS	25
9. RELIABILITY	26
9.1 ERROR RATE	26
9.1.1 <i>Non- Recoverable Error Rate</i>	26
9.1.2 <i>Seek Error Rate</i>	26
9.2 MEAN TIME TO FAILURE (MTTF)	26
9.3 PRODUCT LIFE	26
9.4 REPAIR	26
9.5 PREVENTIVE MAINTENANCE (PM)	26
9.6 LOAD/UNLOAD	27
10. HOST INTERFACE	28
10.1 CABLING	28
10.1.1 <i>Interface Connector</i>	28
10.2 ELECTRICAL SPECIFICATION	29
10.2.1 <i>Cable length and capacitance</i>	29
10.2.2 <i>DC input/output Characteristics</i>	29
10.3 INTERFACE CONNECTOR	30
10.3.1 <i>ATA interface connector</i>	30
10.3.2 <i>Pin Assignment</i>	31
10.3.3 <i>Signal Treatment</i>	32
10.3.4 <i>Series resistance</i>	33
10.3.5 <i>Signal Description</i>	33

10.4	HOST INTERFACE TIMING.....	35
10.4.1	Program I/O Write Timing.....	35
10.4.2	Program I/O Read Timing.....	36
10.4.3	Multiword DMA Write Timing.....	37
10.4.4	Multiword DMA Read Timing.....	38
10.4.5	Ultra DMA Timing.....	39
10.4.6	Reset Timing.....	48
10.5	GROUNDING.....	48
10.6	ADDRESS DECODING.....	49
10.7	REGISTER DESCRIPTION.....	50
10.7.1	Data Register.....	50
10.7.2	Error Register.....	51
10.7.3	Features Register (Write Precompensation Register).....	51
10.7.4	Sector Count Register.....	52
10.7.5	Sector Number Register.....	53
10.7.6	Cylinder Low Registers.....	53
10.7.7	Cylinder High Registers.....	53
10.7.8	Device/Head Register.....	54
10.7.9	Status Register.....	55
10.7.10	Command Register.....	56
10.7.11	Alternate Status Register.....	58
10.7.12	Device Control Register.....	58
10.7.13	Device Address register.....	58
10.8	COMMAND DESCRIPTIONS.....	60
10.8.1	Nop (00h).....	61
10.8.2	Recalibrate (1xh).....	61
10.8.3	Flush Cache (E7h).....	61
10.8.4	Flush Cache EXT (EAh).....	61
10.8.5	Read Sector (20h/21h).....	62
10.8.6	Read Sector EXT (24h).....	62
10.8.7	Write Sector (30h/31h).....	63
10.8.8	Write Sector EXT (34h).....	63
10.8.9	Read Verify (40h).....	64
10.8.10	Read Verify EXT (42h).....	64
10.8.11	Write Verify (3Ch).....	65
10.8.12	Format Track (50h).....	65
10.8.13	Seek (7xh).....	66
10.8.14	Toshiba Specific.....	66
10.8.15	Execute Diagnostics (90h).....	67
10.8.16	Initialize Device Parameters (91h).....	67
10.8.17	Download Microcode (92h).....	68
10.8.18	Read Multiple (C4h).....	69
10.8.19	Read Multiple EXT (29h).....	70
10.8.20	Write Multiple (C5h).....	70
10.8.21	Write Multiple EXT (39h).....	72
10.8.22	Set Multiple Mode (C6h).....	72
10.8.23	Read DMA (C8h/C9h).....	73
10.8.24	Read DMA EXT (25h).....	73
10.8.25	Write DMA (CAh/CBh).....	74
10.8.26	Write DMA EXT (35h).....	74
10.8.27	Power Control (Exh).....	75
10.8.28	Read Buffer (E4h).....	77
10.8.29	Write Buffer (E8h).....	77
10.8.30	Identify Device (ECh).....	77
10.8.31	SET MAX (F9h).....	91
10.8.32	SET MAX ADDRESS EXT (37h).....	94
10.8.33	Read Native Max Address (F8h).....	94
10.8.34	Read Native Max Address EXT (27h).....	95

10.8.35	<i>Set Features (EFh)</i>	96
10.8.36	<i>SECURITY SET PASSWORD (F1h)</i>	97
10.8.37	<i>SECURITY UNLOCK (F2h)</i>	98
10.8.38	<i>SECURITY ERASE PREPARE (F3h)</i>	98
10.8.39	<i>SECURITY ERASE UNIT (F4h)</i>	99
10.8.40	<i>SECURITY FREEZE LOCK (F5h)</i>	99
10.8.41	<i>SECURITY DISABLE PASSWORD (F6h)</i>	100
10.8.42	<i>SMART Function Set (B0h)</i>	100
10.8.43	<i>Read Log EXT (2Fh)</i>	121
10.8.44	<i>Write Log EXT (3Fh)</i>	127
10.8.45	<i>Device Configuration (B1h)</i>	127
10.9	SECURITY MODE FEATURE SET.....	135
10.9.1	<i>Security mode default setting</i>	135
10.9.2	<i>Initial setting of the user password</i>	135
10.9.3	<i>Security mode operation from power-on</i>	136
10.9.4	<i>Password lost</i>	137
10.9.5	<i>Command Table</i>	138
10.10	SELF-MONITORING, ANALYSIS AND REPORTING TECHNOLOGY	139
10.10.1	<i>Attributes</i>	139
10.10.2	<i>Attributes values</i>	139
10.10.3	<i>SMART function default setting</i>	139
10.11	ADAPTIVE POWER MODE CONTROL	140
10.11.1	<i>Performance Idle</i>	140
10.11.2	<i>Active Idle</i>	140
10.11.3	<i>Low Power Idle</i>	140
10.11.4	<i>Transition time</i>	140
10.12	RESET	141
10.13	DRIVE0/DRIVE1 CONFIGURATION	142
10.14	CACHE MEMORY	143
10.14.1	<i>Cache Operations</i>	143
10.14.2	<i>Notes for write cache</i>	143
10.15	AUTOMATIC WRITE REALLOCATION	143
11.	PROTOCOL	144
11.1	PIO DATA IN COMMANDS.....	145
11.2	PIO DATA OUT COMMANDS.....	145
11.3	NON-DATA COMMANDS	147
11.4	DMA DATA TRANSFER COMMANDS.....	149
11.5	ULTRA DMA.....	150
11.6	OTHER TIMINGS.....	153

Table of Figures

FIGURE 1	MK3006GAL DIMENSIONS	20
FIGURE 2	MK6006GAH/MK4006GAH DIMENSIONS	21
FIGURE 3	ATA INTERFACE CONNECTOR	30
FIGURE 4	PASSWORD SET SECURITY MODE POWER-ON FLOW	136
FIGURE 5	USER PASSWORD LOST	137
FIGURE 6	OPTIONAL JUMPER FOR DRIVE0/DRIVE1	142
TABLE 10.3-1	SIGNAL PIN ASSIGNMENT	31
TABLE 10.3-2	SIGNAL TREATMENT	32
TABLE 10.6-1	REGISTER MAP	49
TABLE 10.6-2	DECODE LOGIC	49
TABLE 10.7-1	DIAGNOSTIC MODE ERROR REGISTER	51
TABLE 10.7-2	COMMAND CODE	57
TABLE 10.8-1	IDENTIFY INFORMATION	78
TABLE 10.8-2	IDENTIFY INFORMATION (CONTINUED).....	79
TABLE 10.8-3	IDENTIFY INFORMATION (CONTINUED).....	80
TABLE 10.8-4	IDENTIFY INFORMATION (CONTINUED).....	81
TABLE 10.8-5	IDENTIFY INFORMATION (CONTINUED).....	82
TABLE 10.8-6	SET MAX FEATURES REGISTER VALUES	91
TABLE 10.8-7	SET MAX SET PASSWORD DATA CONTENT.....	92
TABLE 10.8-8	DEVICE CONFIGURATION IDENTIFY DATA STRUCTURE	129
TABLE 10.8-9	DEVICE CONFIGURATION OVERLAY DATA STRUCTURE.....	132
TABLE 10.9-1	SECURITY MODE COMMAND ACTIONS	138
TABLE 10.12-1	INITIALIZATION OF TASK FILE REGISTERS.....	141
TABLE 11.6-1	OTHER TIMINGS.	153

2. SCOPE

This document describes the specifications of the following model, **MK3006GAL** /**MK4006GAH**/**MK6006GAH** of 1.8- inch type Winchester disk drives.

Factory Number	Sales Number
HDD1442	MK3006GAL
HDD1564	MK4006GAH
HDD1544	MK6006GAH

3. GENERAL DESCRIPTION

The MK3006GAL/MK4006GAH/MK6006GAH which is noted hereinafter as “ MK3006GAL/MK4006GAH/MK6006GAH ” or as “ the drive ” comprises a series of intelligent disk drives .

The drive features an ATA-2 / 3 / 4 / 5 / 6 interface embedded controller that requires a simplified adapter board for interfacing to an AT or AT compatible bus. The drives employ Winchester technology and a closed loop servo control system which have made high recording density of 149.6 M bit/mm²(96.5G bit/in²)(MK3006GAL/MK6006GAH), 131.7 M bit/mm²(85.0G bit/in²)(MK4006GAH)and average access time of 15 msec with highest reliability of 300,000 hours for MTTF (Mean Time to Failure) possible.

The drive is distinctive for its small and light body.

The MK3006GAL/MK4006GAH/MK6006GAH consists of an HDA (Head Disk Assembly) and a printed circuit board. The HDA has a sealed module which contains a disk spindle assembly, a head actuator assembly and an air filtration system. This HDA adopts Winchester technology which enhances high reliability. The actuator is a rotary voice coil motor which enables high-speed access.

The disk is driven directly by a DC spindle motor. Air filtration is provided by a high performance air filtration system using both breather and circulation filters.

The drive provides a carriage lock mechanism which is activated automatically upon power down in order to prevent head/media from being damaged when it is not operating or under shipment.

The printed circuit board which is set externally to the HDA and equipped with all the electric circuitry necessary to operate the drive except the head drivers . The power supply and interface signal connectors are mounted on the board. Only the head control IC's are located within the HDA. The circuitry perform the following functions:

Read/Write, Task File Control, Spindle Motor Control, Seek and Head Positioning Servo Control, Abnormal Condition Detection and Shock Sensor Control.

SAFETY

▲ CAUTION

Do not disassemble, remodel or repair.

Disassembly, remodeling or repair may cause injury, failure, or data loss.

NOTE

There is a certain probability of the drive causing failure including data error or data loss.

Take preventive steps such as backing up data etc. without exception in order to prevent loss etc. in cases where data loss may result in loss or damage.

Do not touch the top cover since application of force to it may cause damage to the drive.

Do not stack the drive on another drive or on other parts etc. or stack them on top of it during storage or transportation.

Shock or weight may cause parts distortion etc..

Labels and the like attached to the drive are also used as hermetic sealing for maintenance of its performance.

Do not remove them from the drive.

4. KEY FEATURES

- High capacity in smallest size
 - 1.8 inch-type 2 platters accommodating formatted capacity of 60.0116GB (MK6006GAH)/40.000GB(MK4006GAH),
1 platter accommodating formatted capacity of 30.0058GB(MK3006GAL).
 - Slim (MK3006GAL: 5 mm in height, MK6006GAH: 8mm in height) and light (MK3006GAL: 51 gram in weight, MK6006GAH/MK4006GAH: 62 gram in weight) design.
- Fast access and fast transfer rate
 - Quick spin up of Spindle Motor 3 sec.
 - Average access time 15 msec enabled by optimized balance of a head actuator assembly and an efficiently designed magnet of rotary VCM.
 - Bus transfer rate up to 100 megabytes per second and disk transfer 283 megabits maximum per second,(MK3006GAL/MK6006GAH),265 megabits maximum per second. (MK4006GAH)
 - Read ahead cache and write cache enhancing system throughput.
- Intelligent Interface
 - ATA-2/ATA-3/ATA-4/ATA-5/ATA-6 interface supported.
 - Ultra100 supported.
 - Quick address conversion in translation mode.
 - Translation mode which enables any drive configuration.
 - LBA (Logical Block Address) mode.
 - Multi word DMA, Ultra-DMA modes and Advanced PIO mode supported.
- Data integrity
 - Automatic retries and corrections for read errors.
 - 520 bits computer generated ECC polynomial with 10 bits symbol 24 burst on-the-fly error correction capability.
- High reliability
 - Powerful self- diagnostic capability.
 - Shock detection with shock sensor circuit for high immunity against operating shock up to 4,900 m/s² (500 G).
 - Automatic carriage lock secures heads on the ramp with high immunity against non operating shock up to 14,700 m/s² (1,500G).
- Low power consumption
- Supply voltage: 3.3V

· Low power consumption by Adaptive Power Mode Control .

5. BASIC SPECIFICATION

MODEL	MK3006GAL	MK6006GAH	MK4006GAH
Formatted Capacity (gigabytes)	30.0058	60.0116	40.000
Number of sectors	58,605,120	117,210,240	78,126,048
Servo design method	Sector Servo		
Recording method	60/61 ME2PR4+MNP		
Recording density			
Track / mm (TPI)	4704 (119.5k)		4331 (110k) typ.
Bit / mm (BPI)	31.8k (808k) max.		29.0k (737k) max.
Flux change / mm (FRPI)	32.3k (821k) max.		29.5k (750k) max.
Number of disks	1	2	
Number of data heads	2	4	
Number of user data cylinders	55,728		38,160
Bytes per sector	512		

6. PERFORMANCE

	MK3006GAL	MK6006GAH	MK4006GAH
Access time (msec) <*1>			
Track to track seek <*2>	3		
Average seek <*3>	15		
Max. seek <*4>	26		
Rotation speed (RPM)	4,200 ± 0.1%		
Average Latency Time (msec)	7.14		
Internal Transfer rate (Mbits / sec)	131.1 - 283.3		155 - 265
Host Transfer rate (Mbytes / sec)			
Ultra DMA mode	100		
PIO mode	16.6		
Sector Interleave	1:1		
Track skew	Yes		
Buffer size (Mbytes)	2	2 or 8	2
Cache	Read Ahead Cache Write Cache		
Start time <*5> (Up to Drive Ready)	3.5 sec (Typical) 20 sec (Maximum)		
Recovery time from Stand- by <*5>	3 sec (Typical) 20 sec (Maximum)		
Command Overhead (msec)	1		

<*1> Under the condition of normal voltage, 25°C normal temperature and bottom side down.

<*2> Average time to seek all possible adjacent track without head switching.

<*3> Weighted average time to travel between all possible combination of track calculated as below.

Weighted average access time = [Sum of P(n)*t(n)] / [Sum of P(n)], n = 1 to N.

Where, N ; Total number of tracks.

P(n); Total number of seek for stroke n [= 2*(N - n)].

t(n); Average seek time for stroke n.

Average seek time to seek to stroke n is the average time to 1,000 seeks for stroke n, with random head switch.

<*4> Average time for 1,000 full stroke seeks with random head switches.

<*5> Typical values are for the condition of normal voltage, 25°C normal temperature and placing bottom side down. Maximum values are for all conditions specified in this document.

7. POWER REQUIREMENTS

7.1 Supply Voltage

Allowable voltage	3.3V ± 5%
Allowable noise/ripple	70 mV p-p or less

(note 1) When DC power is interrupted,+3.3V voltage drop must be greater than or equal 0V.

7.2 Power Consumption

	Average(note 1)
	MK3006GAL / MK6006GAH / MK4006GAH
Start	1.2 W Maximum
Seek (note 2)	1.1 W Typical
Read / Write(note 3)	1.1 W Typical
Active idle (note 4)	0.4 W Typical
Low power idle (note 5)	0.3 W Typical
Stand- by (note 6)	0.12 W Typical
Sleep	0.07 W Typical

(note 1) Under normal condition (25°C, 101.3 kPa (1,013 mb)) and 3.3V ± 0%.

(note 2) The seek average current is specified based on three operations per 100 ms.

(note 3) The read/write current is specified based on three operations of 63 sector read/write per 100 ms.

(note 4) Motor is rotating at normal speed but none of Read, Write or Seek is executed.

(note 5) Motor is rotating at normal speed but heads are unloaded on the ramp.

(note 6) Motor is not rotating and heads are unloaded on the ramp.

7.3 Energy Consumption Efficiency

Energy consumption efficiency	(W/GB)	Classification
Power consumption at Low power idle / Capacity MK3006GAL	0.010	D
MK4006GAH	0.0075	E
MK6006GAH	0.005	E

Energy consumption efficiency is calculated in accordance with the law regarding efficiency of energy consumption

:Energy saving law,1979 law number 49.

Calculation of Energy consumption is dividing consumed energy by the capacity.

The consumed energy and capacity shall be measured and specified by the Energy saving low.

8. MECHANICAL SPECIFICATIONS

8.1 Dimension and weight

	MK3006GAL	MK6006GAH/MK4006GAH
Width (mm)	54.0 ±0.2	
Height (mm)	5.0 ± 0.15	8.0 ± 0.15
Depth (mm)	78.5±0.3	
Warpage (mm)		
Interconnected area		
Width (shorter side)	0.15 max.	
Depth (longer side)	0.35 max.	
Substrate area (thickness including warpage)	5.35 max.	8.35 max.
Weight	51 max.	62 max.

Figure 1 and Figure 2 show an outline of the drive.

8.2 Drive Orientation

The drive can be installed in all axes (6 directions).

8.3 Mounting Instructions

SAFETY

NOTE

Take anti-static measures in order to avoid damage to the drive when handling it.
The drive uses parts susceptible to damage due to ESD (electrostatic discharge).
Wear ESD proof wrist strap in accordance with the usage specified when handling a drive that is not in an anti-static protection bag.

Extreme shock to the drive may cause damage to it, data corruption, etc..
Do not subject the drive to extreme shock such as dropping, upsetting or crashing against other objects.

Do not place objects which generate magnetic fields such as magnets, speakers, etc. near the drive.
Magnetism may cause damage to the drive or data loss.

8.3.1 Installation

- 1) The drive should be interconnected or mounted carefully on the surface of 0.1mm or less flatness to avoid excessive distortion.
- 2) The drive can be easily damaged by shocks. In order to prevent the damage, avoid giving shock to the drive.
- 3) Don't apply any force to the top cover.
- 4) The drive contains several parts which may be easily damaged by ESD(Electric Static Discharge). Avoid touching the interface connector pins and surface of PCB.
- 5) The temperature of top cover and the base must always be kept under 65°C to maintain the required reliability. (If the drive runs continuously or spins-up frequently, the temperature of the top cover may rise to 15°C maximum. If the drive is used in ambient temperature of 50 °C or more, it should be kept where adequate ventilation is available to keep the temperature of top cover under 65°C)
- 6) Be careful when removing the drive from the host device. The drive may have heated up during operation.
- 7) Do not disassemble, modify or repair.
- 8) A rattle heard when the drive is moved is not a sign of failure.
- 9) Provision for tying the DC logic ground and the chassis ground together or for separating these ground is user specific.
Agreeable locations of chassis ground are in Figure 1 and Figure 2.

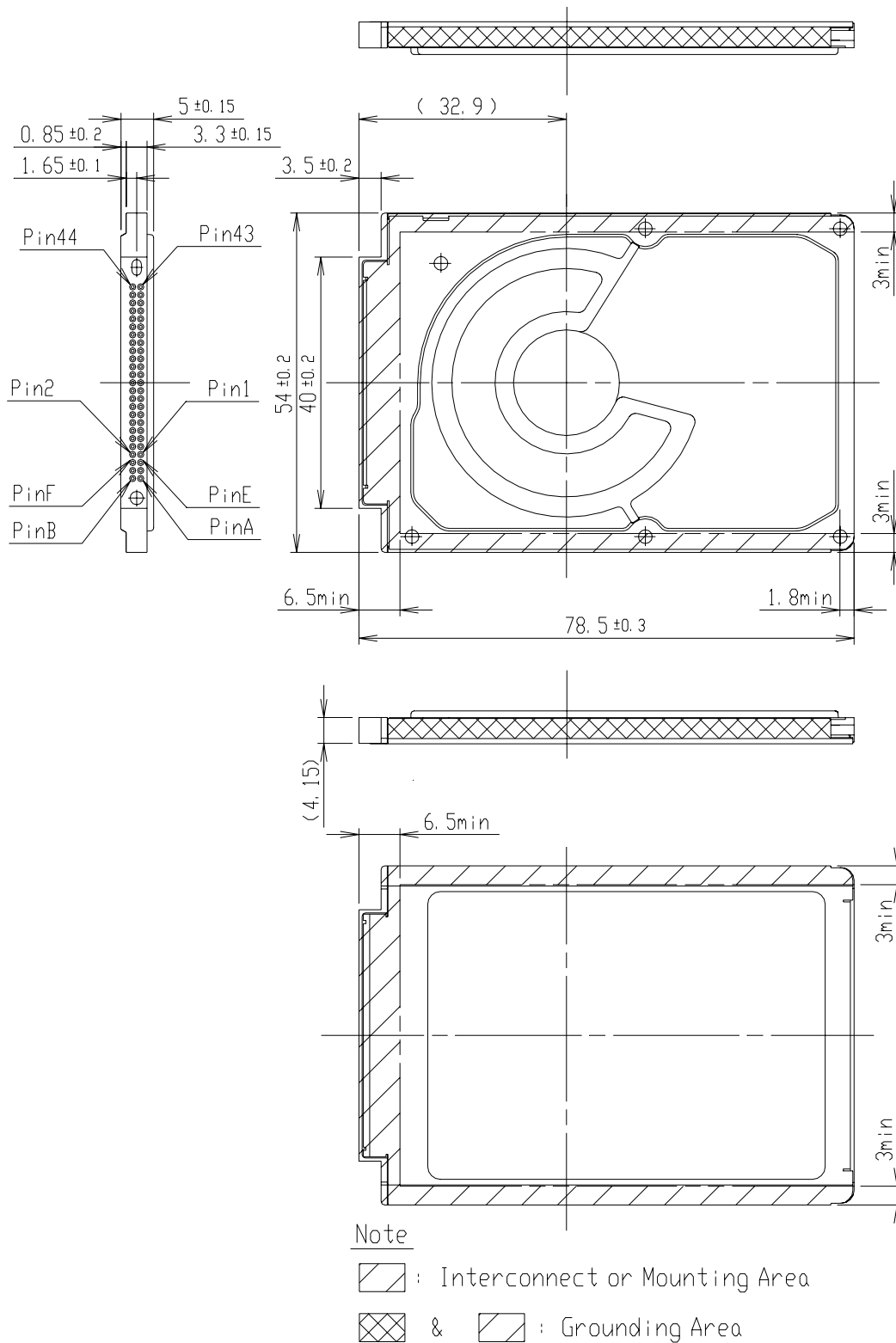

Figure 1 **MK3006GAL Dimensions**

UNIT: mm

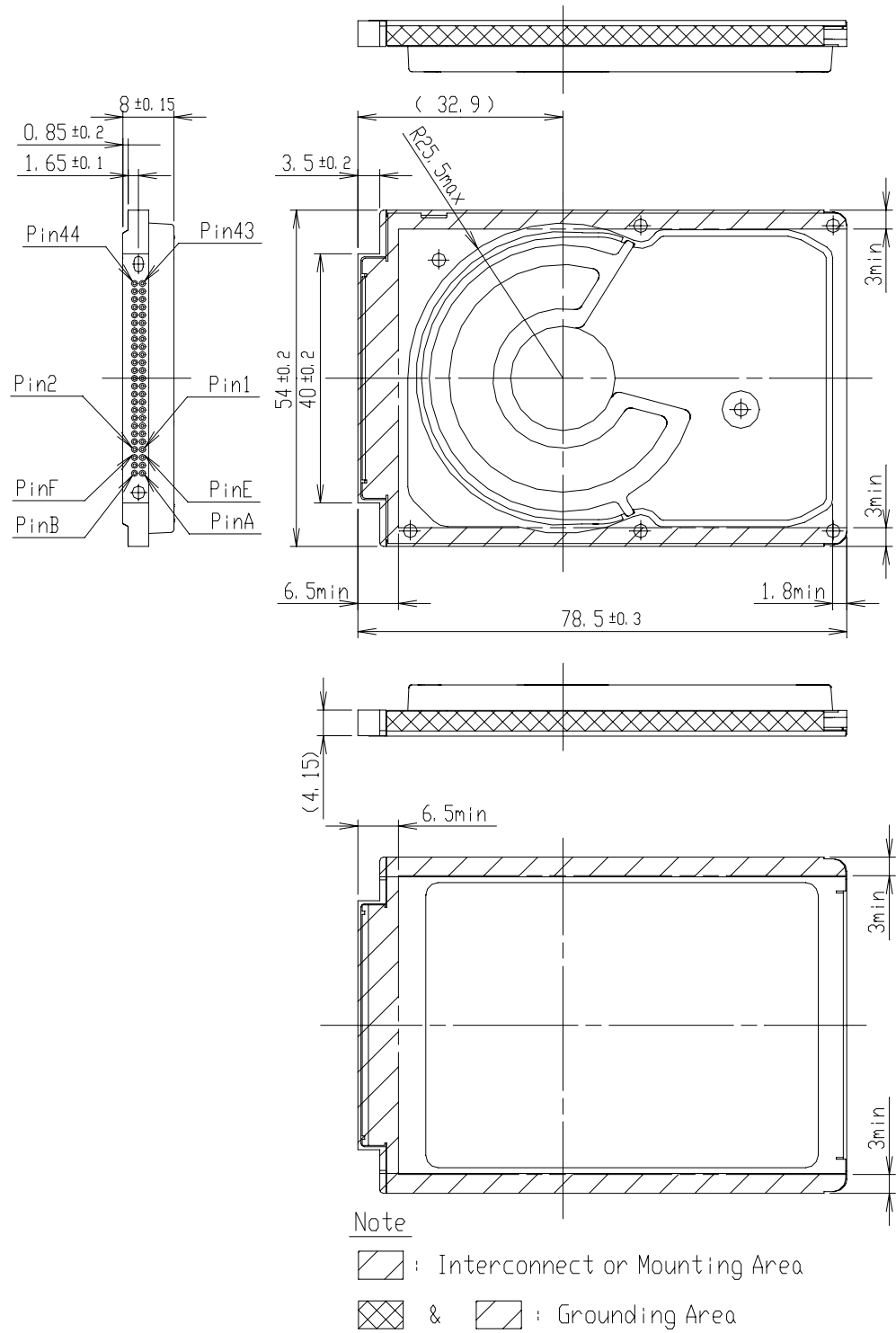

Figure 2 **MK6006GAH/MK4006GAH Dimensions**

UNIT: mm

9. ENVIRONMENTAL LIMITS

9.1 Temperature and Humidity

9.1.1 Temperature

Operating	5°C- 60°C Gradient 15°C / Hour maximum
Non- operating	- 20°C- 65°C Gradient 15°C / Hour maximum
Under shipment	- 40°C- 70°C Gradient 30°C / Hour maximum (Packed in Toshiba's original shipping package.)

The temperature of top cover and base must be kept under 65 at any moment to maintain the desire reliability.

9.1.2 Humidity

Operating	8%- 90% R.H. (No condensation.)
Non- operating	8%- 90% R.H. (No condensation.)
Under shipment	5%- 90% R.H. (Packed in Toshiba's original shipping package.)
Max. wet bulb	29°C (Operating) 40°C (Non- operating)

9.2 Vibration

Operating	4 mm p-p displacement. 5-15 Hz No unrecoverable error. 19.6 m/s ² (2.0G) 15- 500 Hz Sine wave sweeping 1 oct./ minute No unrecoverable error.
Non operating	10 mm p-p displacement. 5-15 Hz No unrecoverable error. 49 m/s ² (5.0G) 15- 500 Hz Sine wave sweeping 1 oct./ minute No unrecoverable error.

9.3 Shock

Operating	4,900 m/s ² (500G) 2 msec half sine wave Repeated twice maximum / second No unrecoverable error.
Non- operating	14,700 m/s ² (1500G) 1 msec half sine wave Repeated twice maximum / second No unrecoverable error.
Under shipment	70 cm free drop No unrecoverable error. Apply shocks in each direction of the drive's three mutually perpendicular axes, one axis at a time. (Packed in Toshiba's original shipping package.)

9.4 Altitude

Operating	- 300 m to 3,000 m
Non operating	- 400 m to 15,000 m

9.5 Acoustics (Sound Power)

MK3006GAL	MK6006GAH/ MK4006GAH	
16dB	18dB	For idle mode (Spindle in rotating).
22dB	24dB	<p>Randomly select a track to be sought in such a way that every track has equal probability of being selected. Seek rate(n_s) is defined by the following formula:</p> $n_s = 0.4 / (t_T = t_L)$ <p>t_T is published time to seek from one random track to another without including rotational latency; t_L is the time for the drive to rotate by half a revolution.</p>









Measurements are to be taken in accordance with ISO 7779.





9.6 Safety Standards

The drive satisfies the following standards .

	MK3006GAL	MK6006GAH/MK4006GAH
Underwriters Laboratories	(UL) 1950	
Canadian Standard Association	(CSA)C22.2 No.950	
TUV Rheinland	EN 60 950	
Bureau of Standards, Metrology and Inspection	D33003	
Ministry of Information and Communication	(Note1)	

(Note 1) Marks of Ministry of Information and Communication

	MK3006GAL	MK6006GAH
Made in Japan	 <ol style="list-style-type: none"> 1. 기기의 명칭(모델명) : MK3006GAL 2. 인증번호 : E-H011-04-2071(B) 3. 인증받은 자의 상호 : TOSHIBA CORPORATION 4. 제조년월일 : 2004-05 5. 제조자 / 제조국가 : TOSHIBA CORPORATION / 일본 	 <ol style="list-style-type: none"> 1. 기기의 명칭(모델명) : MK6006GAH 2. 인증번호 : E-H011-04-2071(B) 3. 인증받은 자의 상호 : TOSHIBA CORPORATION 4. 제조년월일 : 2004-06 5. 제조자 / 제조국가 : TOSHIBA CORPORATION / 일본
Made in Philippines	 <ol style="list-style-type: none"> 1. 기기의 명칭(모델명) : MK3006GAL 2. 인증번호 : E-H011-04-2071(B) 3. 인증받은 자의 상호 : TOSHIBA CORPORATION 4. 제조년월일 : 2004-05 5. 제조자 / 제조국가 : TOSHIBA CORPORATION / 필리핀 	 <ol style="list-style-type: none"> 1. 기기의 명칭(모델명) : MK6006GAH 2. 인증번호 : E-H011-04-2071(B) 3. 인증받은 자의 상호 : TOSHIBA CORPORATION 4. 제조년월일 : 2004-06 5. 제조자 / 제조국가 : TOSHIBA CORPORATION / 필리핀
Made in China	 <ol style="list-style-type: none"> 1. 기기의 명칭(모델명) : MK3006GAL 2. 인증번호 : E-H011-04-2071(B) 3. 인증받은 자의 상호 : TOSHIBA CORPORATION 4. 제조년월일 : 2004-05 5. 제조자 / 제조국가 : TOSHIBA CORPORATION / 중국 	 <ol style="list-style-type: none"> 1. 기기의 명칭(모델명) : MK6006GAH 2. 인증번호 : E-H011-04-2071(B) 3. 인증받은 자의 상호 : TOSHIBA CORPORATION 4. 제조년월일 : 2004-06 5. 제조자 / 제조국가 : TOSHIBA CORPORATION / 중국
Made in Indonesia	 <ol style="list-style-type: none"> 1. 기기의 명칭(모델명) : MK3006GAL 2. 인증번호 : E-H011-04-2071(B) 3. 인증받은 자의 상호 : TOSHIBA CORPORATION 4. 제조년월일 : 2004-05 5. 제조자 / 제조국가 : TOSHIBA CORPORATION / 인도네시아 	 <ol style="list-style-type: none"> 1. 기기의 명칭(모델명) : MK6006GAH 2. 인증번호 : E-H011-04-2071(B) 3. 인증받은 자의 상호 : TOSHIBA CORPORATION 4. 제조년월일 : 2004-06 5. 제조자 / 제조국가 : TOSHIBA CORPORATION / 인도네시아

	MK4006GAH	
Made in Japan	 <ol style="list-style-type: none"> 1. 기기의 명칭(모델명) : MK4006GAH 2. 인증번호 : E-H011-04-2071(B) 3. 인증받은 자의 상호 : TOSHIBA CORPORATION 4. 제조년월일 : 2004-08 5. 제조자 / 제조국가 : TOSHIBA CORPORATION / 일본 	
Made in Philippines	 <ol style="list-style-type: none"> 1. 기기의 명칭(모델명) : MK4006GAH 2. 인증번호 : E-H011-04-2071(B) 3. 인증받은 자의 상호 : TOSHIBA CORPORATION 4. 제조년월일 : 2004-08 5. 제조자 / 제조국가 : TOSHIBA CORPORATION / 필리핀 	
Made in China	 <ol style="list-style-type: none"> 1. 기기의 명칭(모델명) : MK4006GAH 2. 인증번호 : E-H011-04-2071(B) 3. 인증받은 자의 상호 : TOSHIBA CORPORATION 4. 제조년월일 : 2004-08 5. 제조자 / 제조국가 : TOSHIBA CORPORATION / 중국 	
Made in Indonesia	 <ol style="list-style-type: none"> 1. 기기의 명칭(모델명) : MK4006GAH 2. 인증번호 : E-H011-04-2071(B) 3. 인증받은 자의 상호 : TOSHIBA CORPORATION 4. 제조년월일 : 2004-08 5. 제조자 / 제조국가 : TOSHIBA CORPORATION / 인도네시아 	

EMC Adaptability

The drive satisfies the following standards .

	MK3006GAL	MK6006GAH/MK4006GAH
EN5008M1-E1	EN55022 : 1998 Class B	
EN50081-1	EN61000-3-2 : 1995	
	EN61000-3-3 : 1995	
EN55024	EN61000-4-2 : 1995	
	EN61000-4-3 : 1995	
	ENV50204 : 1995	
	EN61000-4-4 : 1995	
	EN61000-4-5 : 1995	
	EN61000-4-6 : 1996	
	EN61000-4-11 : 1994	

9.7 Magnetic Fields

The disk drive shall work without degradation of the soft error rate under the following Magnetic Flux Density Limits at the enclosure surface.

MK3006GAL/ MK6006GAH/MK4006GAH	0.6mT(6Gauss)
-----------------------------------	---------------

10. RELIABILITY

A failure is defined as an inability of the drive to perform its specified function described in the requirements of this document when being operated under the normal conditions or conditions specified in this document. However, damages caused by operation mistake, mishandling, accidents, system errors and other damages that can be induced by the customers are not defined as failure.

10.1 Error Rate

10.1.1 Non- Recoverable Error Rate

1 error per 10^{13} bits read

The defective sectors allocated to the spare locations in the factory are not counted in the error rate.

10.1.2 Seek Error Rate

1 error per 10^6 seeks

A seek error is a positioning error recoverable by a retry including recalibration.

10.2 Mean Time to Failure (MTTF)

A failure means that the drive can not execute the function defined in this document under the nominal temperature, humidity and the other conditions specified in this document. Damages caused by operation mistake, mishandling, system failure and other damages occurred under the conditions which are not described in this document are not considered as the failure.

MTTF	300,000 hours
Conditions	
Power on hours	2,800 hours (200 days x 14 hours) / year
Operating hours	600 hours (200 days x 3 hours) / year
Seek hours	1.30×10^6 seeks / month
Number of load / unload	70 times / hour (60,000 times / year)
Environment	Normal (25°C, 101.3 kPa (1,013 mb))

10.3 Product Life

5 years or 20,000 power on hours whichever comes earlier
--

10.4 Repair

A defective drive should be replaced. Parts and subassemblies should not be repaired individually.

10.5 Preventive Maintenance (PM)

No preventive maintenance is required.

10.6 Load/Unload

Be sure to issue and complete the following commands for unloading before cutting off the power supply.

Following table shows the specification for normal load/unload cycles.

Load/unload cycle (Times)	Environment
600,000	Room temperature
300,000	Operational temperature range

Unload is executed by the following commands :

- Standby
- Standby Immediate
- Sleep
- Hard reset

Load/Unload is also executed as one of the idle modes of the drive.

If the power supply is cut when the head is on a media, Emergency Unload is performed by routing the back-EMF of SPM to the voice coil. In this case, Emergency Unload is performed 20,000 times maximum. Emergency Unload should be used only when the host-system cannot perform normal operation.

11. HOST INTERFACE

Related Standards

Information technology - AT Attachment Interface with Extensions (ATA-2)
X3T10.279-199x

Information technology - AT Attachment-3 Interface (ATA-3)
X3T10/2008D Revision 6 October 26, 1995

Information technology - AT Attachment with Packet Interface Extension (ATA -4)
T13/1153D Revision 17 October 30, 1997

Information technology - AT Attachment with Packet Interface-5 Interface-5 (ATA-5)
T13/1321D Revision 2 December 13, 1999

Information technology - AT Attachment with Packet Interface-6 (ATA-6)
T13/1410D Revision 3b February 26, 2002

11.1 Cabling

11.1.1 Interface Connector

Drive side connector	DDK Ltd, MCD-D50SA-3
Recommended host side connector	DDK Ltd, MCD-D50P*-X * : B, C, D the difference of connector height

11.2 Electrical specification

11.2.1 Cable length and capacitance

0.46m MAX	35pF MAX
-----------	----------

11.2.2 DC input/output Characteristics

11.2.2.1 Input

item	Unit	value
voltage high (note 1)	V	2.0 to 5.5
low	V	-0.3 to 0.8
leak current	μ A	± 10 (note 2)

As non-connected logic voltage, input voltage level is from -0.3V to 0.5V.

(note 1) The max. input range of signal is from -0.3V to 5.5V .

(note 2) Except for signal lines pulled up as shown in Table 10.3.3-1

11.2.2.2 Output

item	unit	value	Note
voltage high	V	2.4 min.	$I_{OH} = -1\text{mA}$
low	V	0.4 max.	$I_{OL} = 4\text{mA}$

11.3 Interface connector

11.3.1 ATA interface connector

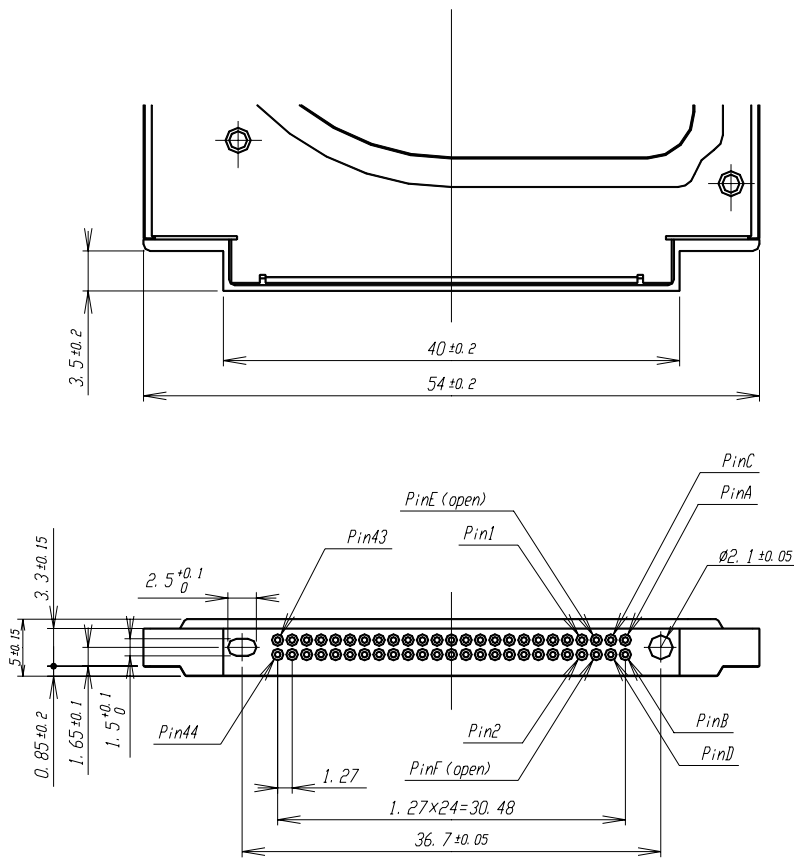

UNIT:mm

Figure 3 ATA interface connector

11.3.2 Pin Assignment

The following table describes all of the pins on the Task File Interface.

Table 11.3-1 Signal pin assignment

PIN No.	SIGNALS	PIN No.	SIGNALS
1	- RESET	2	GROUND
3	DD 7	4	DD 8
5	DD 6	6	DD 9
7	DD 5	8	DD 10
9	DD 4	10	DD 11
11	DD 3	12	DD 12
13	DD 2	14	DD 13
15	DD 1	16	DD 14
17	DD 0	18	DD 15
19	GROUND	20	OPEN
21	DMARQ	22	GROUND
23	- DIOW STOP	24	GROUND
25	-DIOR -DMARDY HSTROBE	26	GROUND
27	IORDY -DMARDY -DSTROBE	28	CSEL
29	-DMACK	30	GROUND
31	INTRQ	32	- IOCS16
33	DA 1	34	- PDIAG / -CBLID
35	DA 0	36	DA 2
37	- CS0	38	- CS1
39	- DASP	40	GROUND
41	+ 3.3V	42	+ 3.3V
43	GROUND	44	RESERVED

Note) Symbol (-) in front of signal name shows negative logic.

11.3.3 Signal Treatment

Driver types and requirements for the signal pull-up and down are as follows. Resistor requirement is minimum for the host. - IO16 is pulled up in the drive with certain value so that the Vol is obtained to run with a host that has large value of pull up resistor. - CS0 and - CS1 are also pulled up for better noise immunity.

Table 11.3-2 Signal treatment

SIGNAL	Driven by	TYPE	By host	By drive
- RESET	Host	TP		10k PU
DD 0:15	bi-direction	TS		
DMARQ	Drive	TS	5.6 k Ω PD	
- DIOR -DMARDY HSTROBE	Host	TS		
- DIOW STOP	Host	TS		
IORDY -DDMARDY DSTROBE	Drive	TS	4.7 k Ω PU	
CSEL	Host		GND	10 k Ω PU
- DMACK	Host	TP		
INTRQ	Drive	TS	10 k Ω PD	
- IOCS16	Drive	OD	1.0 k Ω PU	1.2 k Ω PU
DA 0:2	Host	TP		
- PDIAG /	Drive	TS		10 k Ω PU
- CS0 - CS1	Host	TP		
- DASP	Drive	OD		10 k Ω PU

TP = Totem Pole, TS = Tri-State, PD = Pull Down, PU = Pull-Up, OD = Open Drain

11.3.4 Series resistance

Each signal has its own series resistance.

SIGNAL	SERIAL RESISTANCE VALUE
-DIOR -HDMARDY HSTROBE	82
-DIOW STOP	82
-CS0, -CS1	82
DA0,DA1,DA2	82
-DMACK	82
DMARQ	22
INTRQ	22
IORDY -DDMARDY DSTROBE	22
DD 0 ~ DD15	33

11.3.5 Signal Description

SIGNAL	DIR.	PIN	DESCRIPTION
- RESET	O (*1)	1	Reset signal from the host system; It shall be active low when system is powered-up or when voltage fault is detected.
DD 15- 0	I/O	18- 3	16 bit bi- directional data bus between the host system and the drive. All 16 bits are used for data transfer in the data register. The lower 8 bits, HD0- HD7, are used for the other register and ECC access.
KEY	N/C	20	Pin position 20 has no connection pin, clipped on the drive and plugged on the cable in order to ensure correct orientation of the cable and to avoid wrong insertion.
DMARQ	I	21	DMA request signal is set by the drive to indicate that the DMA data transfer is ready. The direction of the data transfer is controlled by write/read strobe signal (HOST IOW or HOST IOR). This signal is used on a hand shake manner with -DMACK.
- DIOW STOP	O	23	Write strobe. The rising clocks data from the host data bus, HD0 through HD15 to a register or data register of the drive. Stop signal used by the host after the completion of Ultra DMA Burst.
- DIOR -HDMARDY HSTROBE	O	25	Read strobe. When active low, this signal enables data from a register or the data of the drive onto the host data bus, HD0 through HD15. The rising edge of -HOST IOR latches on the data on the bus from the drive. This signal is for reporting the drive that the host system is ready to accept Ultra DMA data. Strobe. HSTROBE indicates that the host transfers ULTRA DMA data. The rising edge and the falling edge of HSTROBE enable the drive to latch the data.
IORDY -DDMARDY DSTROBE	I	27	IORDY reports host that the BUS is available. -DDMARDY is asserted to indicate that the drive is ready to receive the Ultra DMA data. Strobe. DSTROBE is asserted to indicate that the drive transfers Ultra DMA data. The rising edge and falling edge of DSTROBE enable the host to latch the data.

CSEL	O	28	If jumper pins B through D are assigned, Master/Slave setting with this pin is valid. When grounded, the drive recognizes itself as a Master. When not grounded, the drive recognizes itself as a Slave.
- DMACK	O	29	Responding to DMARQ, this signal indicates that the host is ready to receive or send the data.
INTRQ	I	31	Interrupt to the host system, enabled only when the drive is selected and the host activates the - IEN bit in the Device Control register. When the - IEN bit is inactive or the drive is not selected, this output is in a high impedance state, whether an interrupt is set or not. The interrupt is set when the IRQ bit is set by the drive CPU. IRQ is reset to zero when host reads the Status register or a write to the command register or when DRQ is negated.
- IOCS16	I	32	Indication to the host system that the 16 bit data register has been addressed and that the drive is ready to send or receive a 16 bit data word (open drain).
DA 1	O	33	Address line from the host system to select the registers of the drive.
- PDIAG / CBLID	I/O	34	In Master/Slave mode, this signal reports the presence of slave drive to master drive and enables transmitting of diagnostic result between master drive and slave drive
DA 0	O	35	Address line from the host system to select the registers of the drive.
DA 2	O	36	Address line from the host system to select the registers of the drive.
- CS0	O	37	Chip select signal generated from the host address bus. This signal is used to select one of the two groups of host accessible registers.
- CS1	O	38	Chip select signal generated from the host address bus. This signal is used to select one of the two groups of host accessible registers.
- DASP	I	39	This is a signal from the drive used either to drive an external LED whenever the drive is being accessed, or to report presence of the slave drive to the master when the drive is in master/slave mode.
RESERVED		27,44	Reserved for future use. No connection.
+ 3.3V		41,42	Power line.
GROUND		2,19 22,24 26,30 40,43	Ground between the drive and the host system.

(*1) 'I' is from the drive to the host system, 'O' is from the host system to the drive, and 'I/O' is bi-directional.

11.4 Host Interface Timing

11.4.1 Program I/O Write Timing

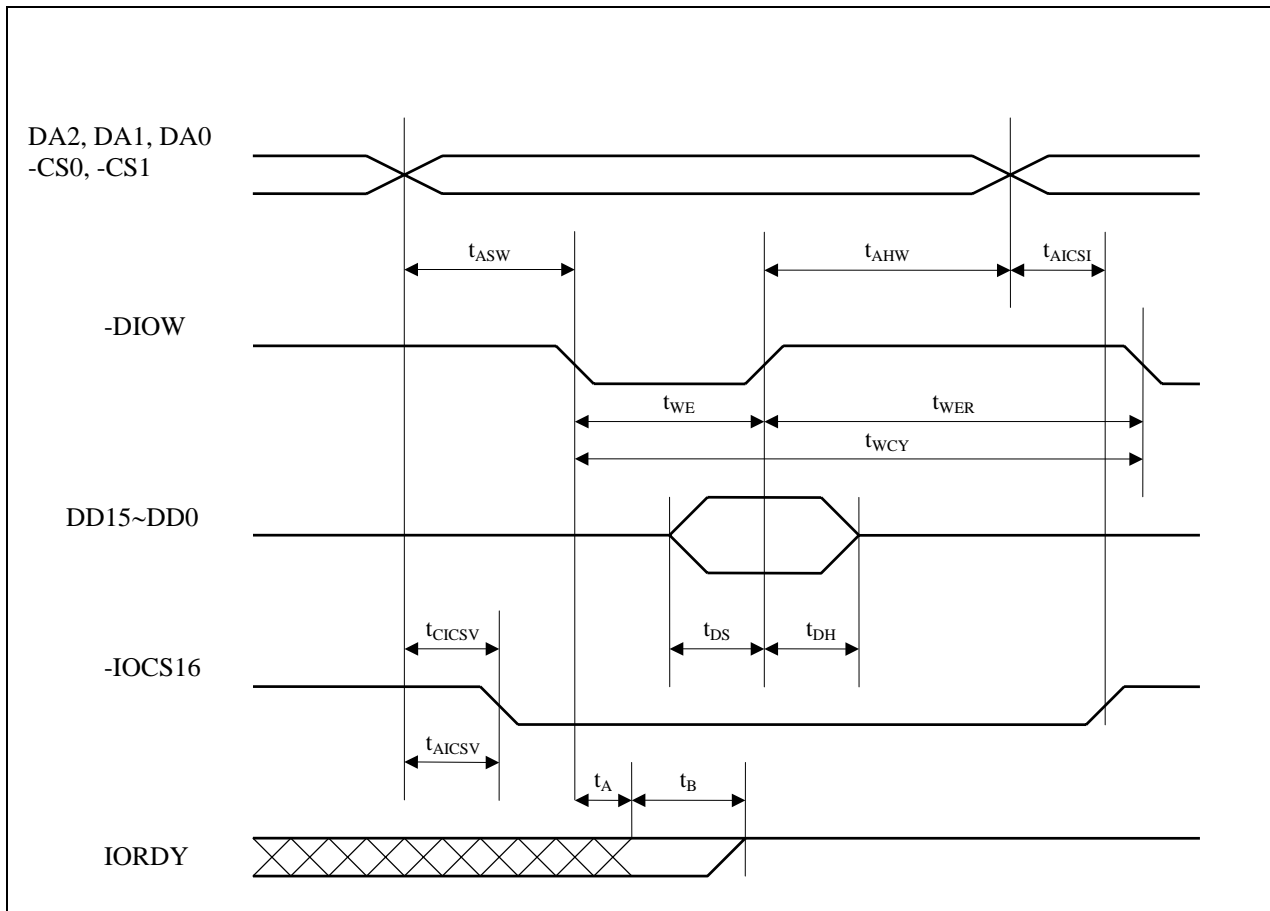

Symbol	Meaning		Transfer mode				
			0	1	2	3	4
t_{ASW}	Address Setup to \overline{DOW} Low	(min.)	70	50	30	30	25
t_{DS}	Data Setup to \overline{DOW} High	(min.)	60	45	30	30	20
t_{WE}	\overline{DOW} Pulse Width	(min.)	165	125	100	80	70
t_{DH}	Data Hold from \overline{DOW} High	(min.)	30	20	15	10	10
t_{AHW}	ADDR Hold from \overline{DOW} High	(min.)	20	15	10	10	10
t_{WER}	\overline{DOW} Inactive	(min.)	-	-	-	70	25
t_{WCY}	Write Cycle Time	(min.)	600	383	240	180	120
t_{CICSV}	$\overline{IOCS16}$ valid from \overline{CS}	(max.)	90	50	40	n/a*	n/a*
t_{AICSV}	$\overline{IOCS16}$ valid from address	(max.)	90	50	40	n/a*	n/a*
t_{AICSI}	$\overline{IOCS16}$ inactive from address	(max.)	60	45	30	n/a*	n/a*
t_A	IORDY Setup time	(max.)	35	35	35	35	35
t_B	IORDY Pulse Width	(max.)	1250	1250	1250	1250	1250

(*) $\overline{IOCS16}$ shall be specified in ATA-2 specifications. For other modes, this signal is invalid. The Drive releases $\overline{IOCS16}$ within the time of t_{AICSI} , but how much time it takes to turn to inactive condition is determined by pull up resistance, output impedance and line capacitance.

11.4.2 Program I/O Read Timing

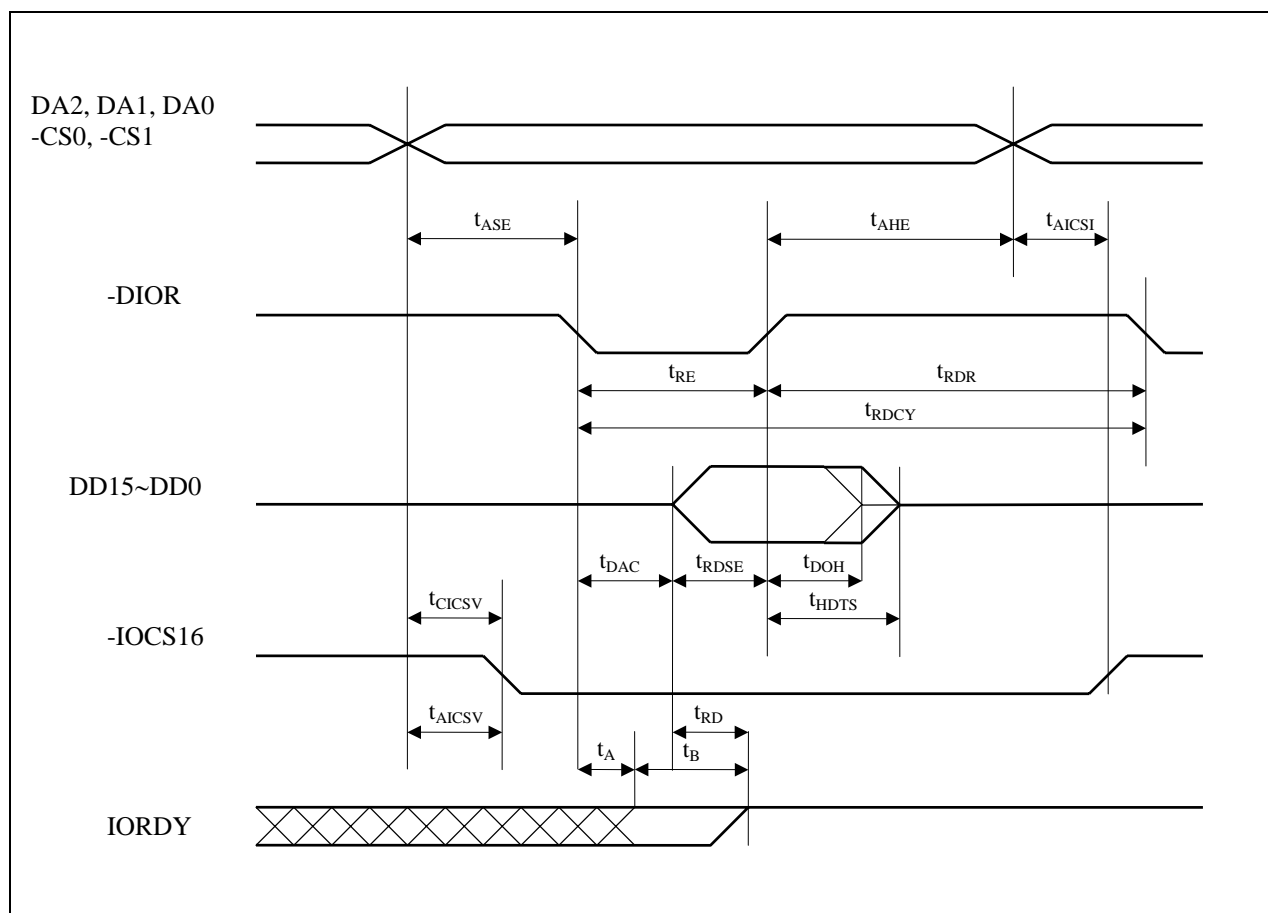

Symbol	Meaning		Transfer mode				
			0	1	2	3	4
t_{ASE}	Address Setup to -DIOR Low	(min.)	70	50	30	30	25
t_{RE}	-DIOR Pulse Width	(min.)	165	125	100	80	70
t_{RDSE}	-DIOR data setup	(min.)	50	35	20	20	20
t_{DOH}	Data Hold from -DIOR High	(min.)	5	5	5	5	5
t_{HDTS}	Data Tri-state from -DIOR High	(max.)	30	30	30	30	30
t_{AHE}	ADDR Hold from -DIOR High	(min.)	20	15	10	10	10
t_{RDR}	-DIOR Inactive	(min.)	-	-	-	70	25
t_{RDCY}	Read Cycle Time	(min.)	600	383	240	180	120
t_{CICSV}	-IOCS16 valid from -CS	(max.)	90	50	40	n/a*	n/a*
t_{AICSV}	-IOCS16 valid from address	(max.)	90	50	40	n/a*	n/a*
t_{AICSV}	-IOCS16 inactive from address	(max.)	60	45	30	n/a*	n/a*
t_{RD}	Read Data Valid to IORDY	(min.)	0	0	0	0	0
t_A	IORDY Setup time	(max.)	35	35	35	35	35
t_B	IORDY Pulse Width	(max.)	1250	1250	1250	1250	1250

(*) -IOCS16 is specified in ATA-2 specifications. For other modes, this signal is invalid. Drive releases -IOCS16 within the time of t_{AICSV} , but how long it takes to turn to inactive condition is defined by pull up resistance, output impedance and line capacitance.

11.4.3 Multiword DMA Write Timing

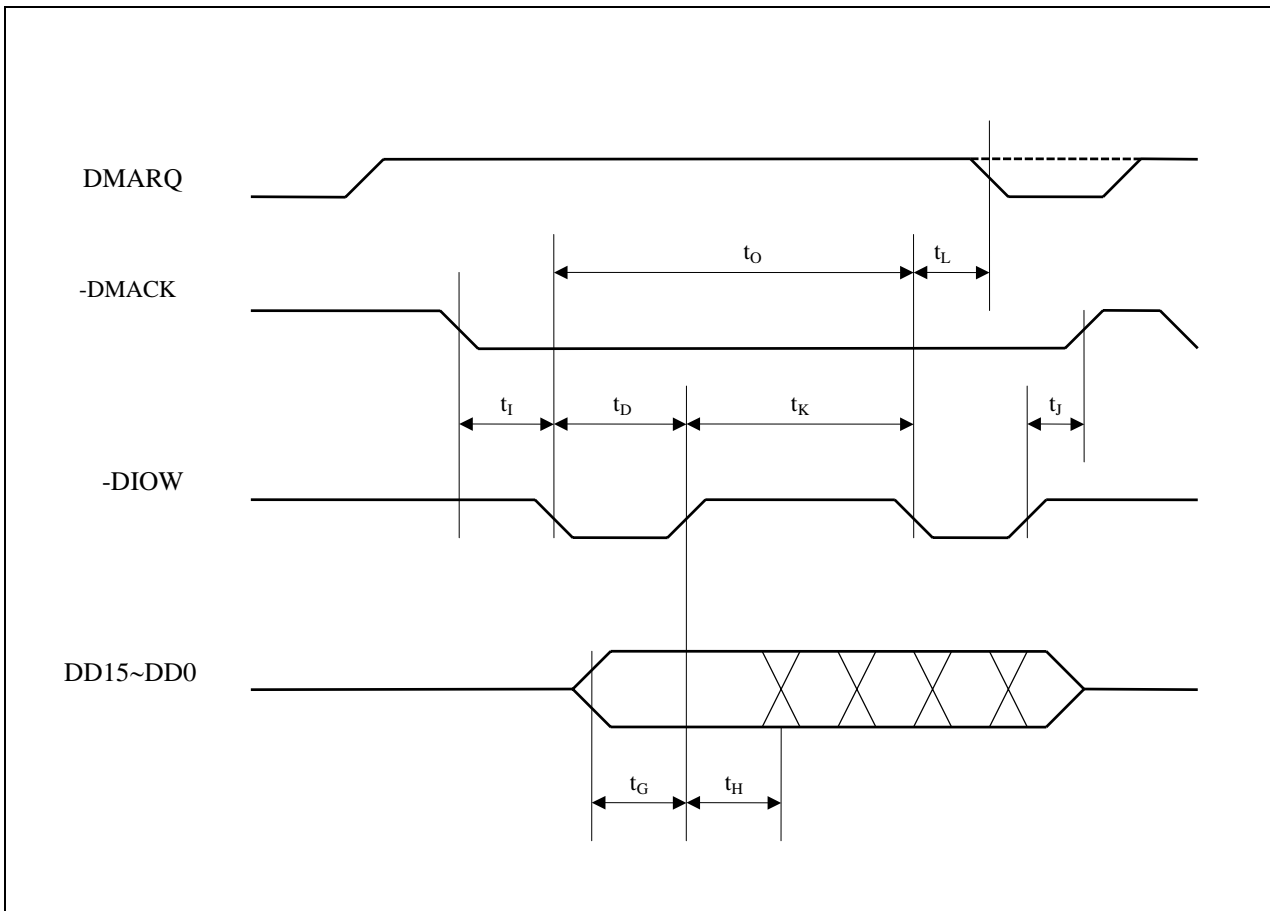

ATA/ATAPI-6 SPECIFICATIONS

Symbol	Transfer mode Meaning	MODE 0		MODE 1		MODE 2	
		Min.	Max.	Min.	Max.	Min.	Max.
t_0	Cycle time	480		150		120	
t_c	DMACK to DMARQ delay		---		---		---
t_D	-DIOW 16-bit	215		80		70	
t_G	-DIOW data setup	100		30		20	
t_H	-DIOW data hold	20		15		10	
t_I	DMACK to -DIOW setup	0		0		0	
t_J	-DIOW to DMACK hold	20		5		5	
t_K	-DIOW negated pulse width	215		50		25	
t_L	-DIOW to DMARQ delay		40		40		35

11.4.4 Multiword DMA Read Timing

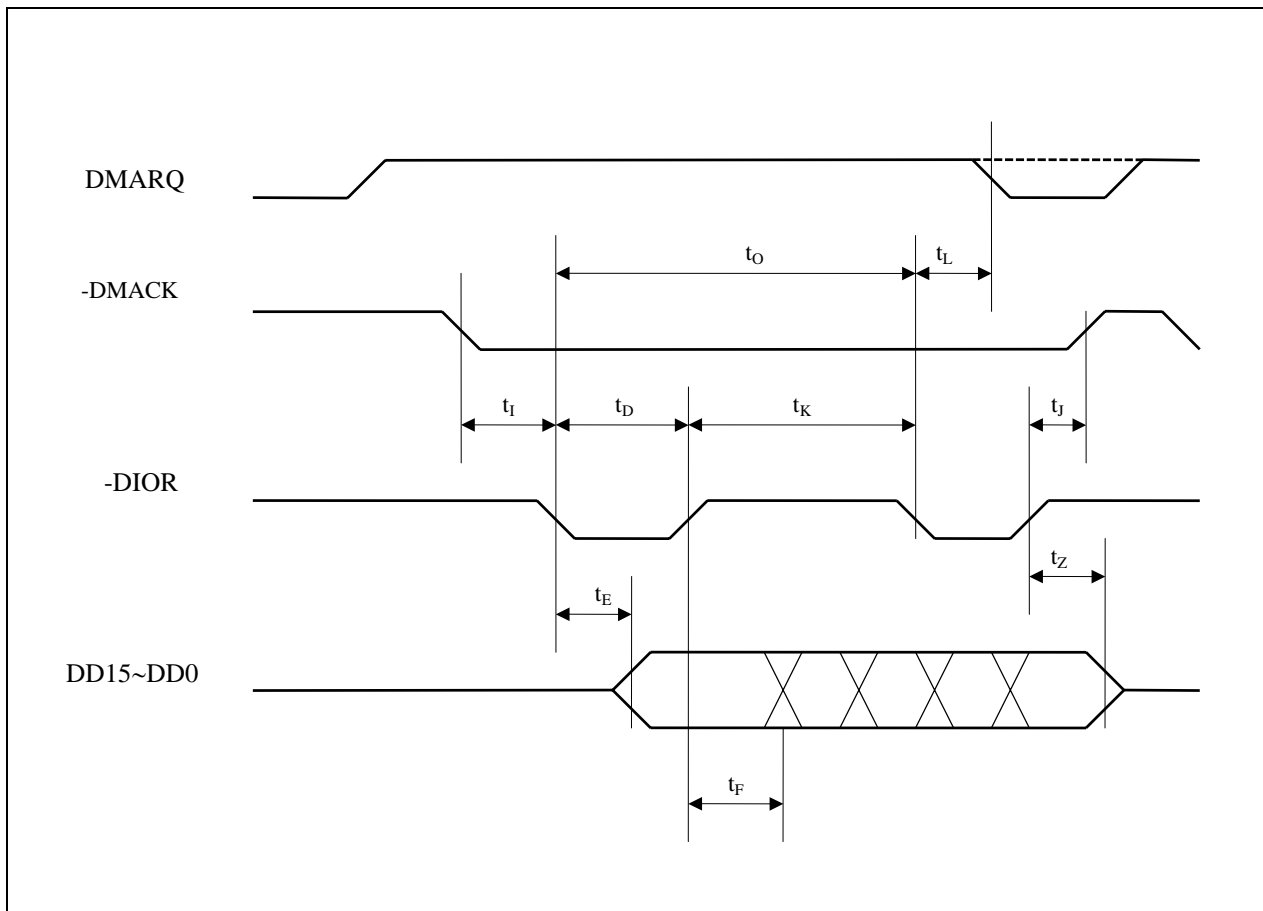

ATA/ATAPI-6 SPECIFICATIONS

Symbol	Transfer mode Meaning	MODE 0		MODE 1		MODE 2	
		Min.	Max.	Min.	Max.	Min.	Max.
t_0	Cycle time	480		150		120	
t_c	DMACK to DMARQ delay		---		---		---
t_D	-DIOR 16-bit	215		80		70	
t_E	-DIOR data access		150		60		50
t_F	-DIOR data hold	5		5		5	
t_Z	-DIOR to tristate		20		25		25
t_I	DMACK to -DIOR setup	0		0		0	
t_J	-DIOR to DMACK hold	20		5		5	
t_K	-DIOR negated pulse width	50		50		25	
t_L	-DIOR to DMARQ delay		120		40		35

11.4.5 Ultra DMA Timing

Initiating an Ultra DMA data in burst

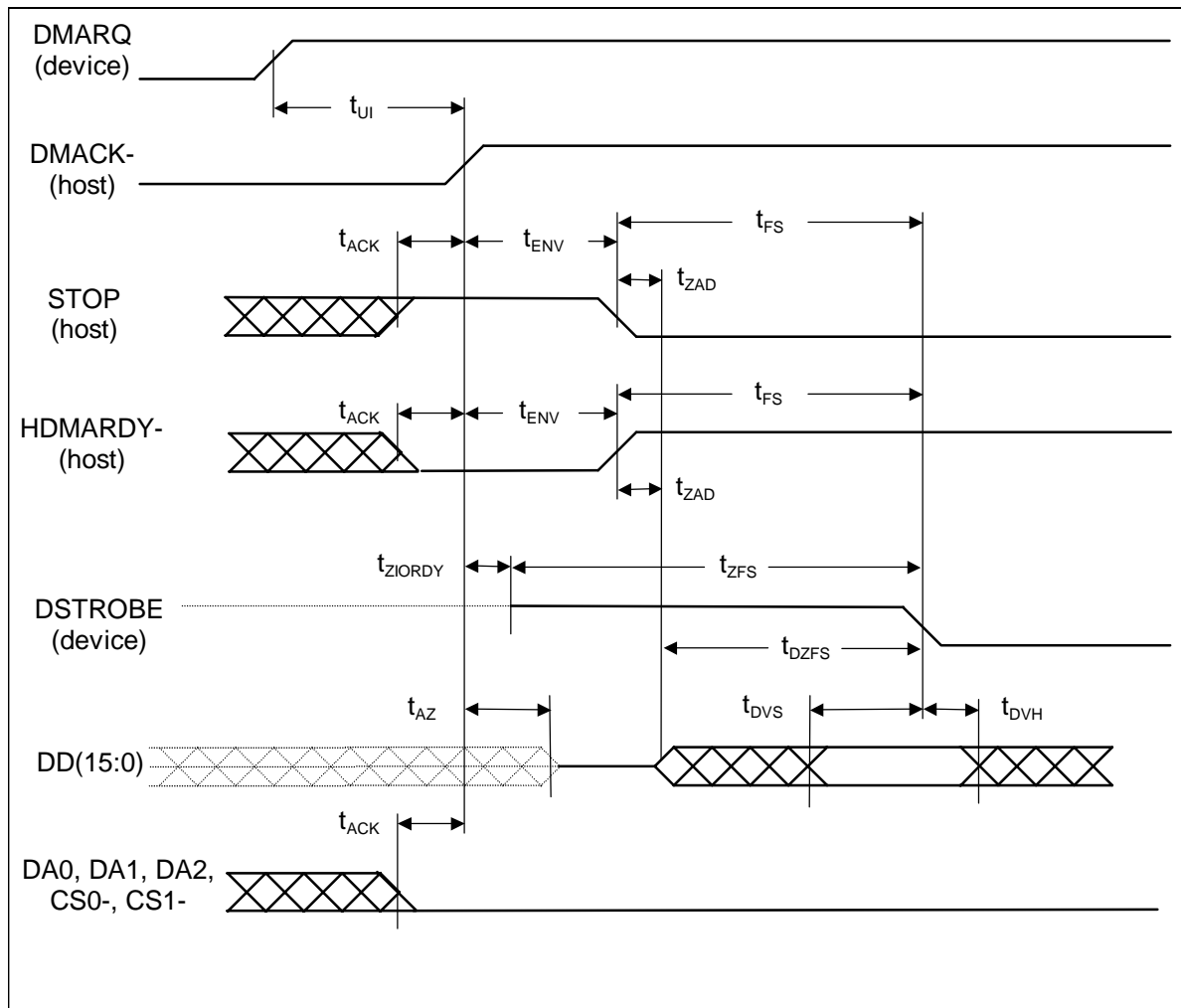

Sustained Ultra DMA data in burst

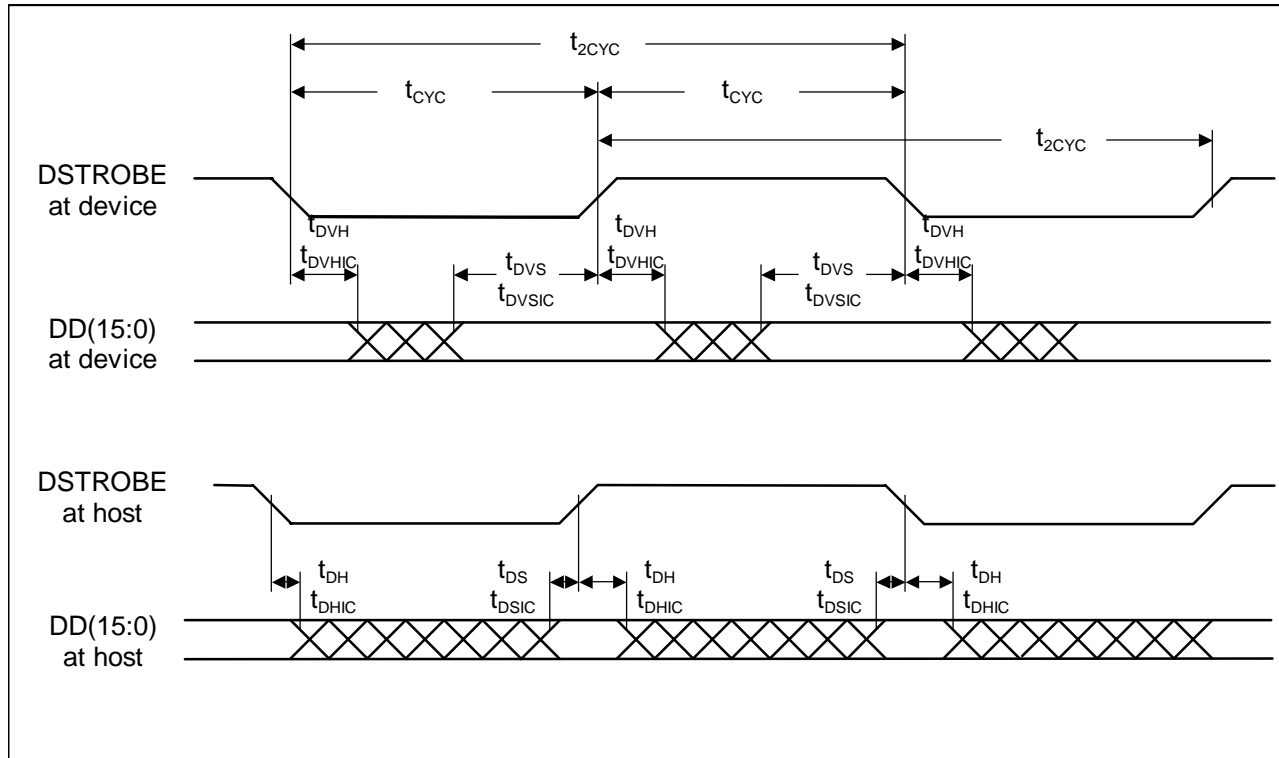

Host pausing an Ultra DMA data in burst

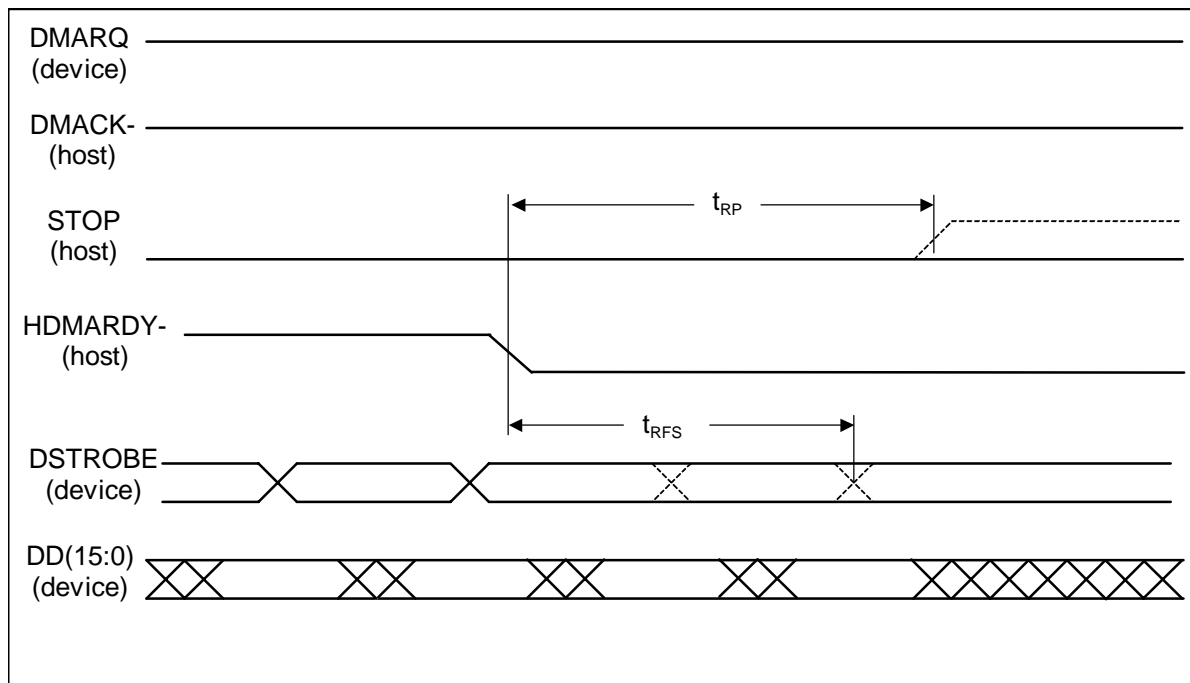

Device terminating an Ultra DMA data in burst

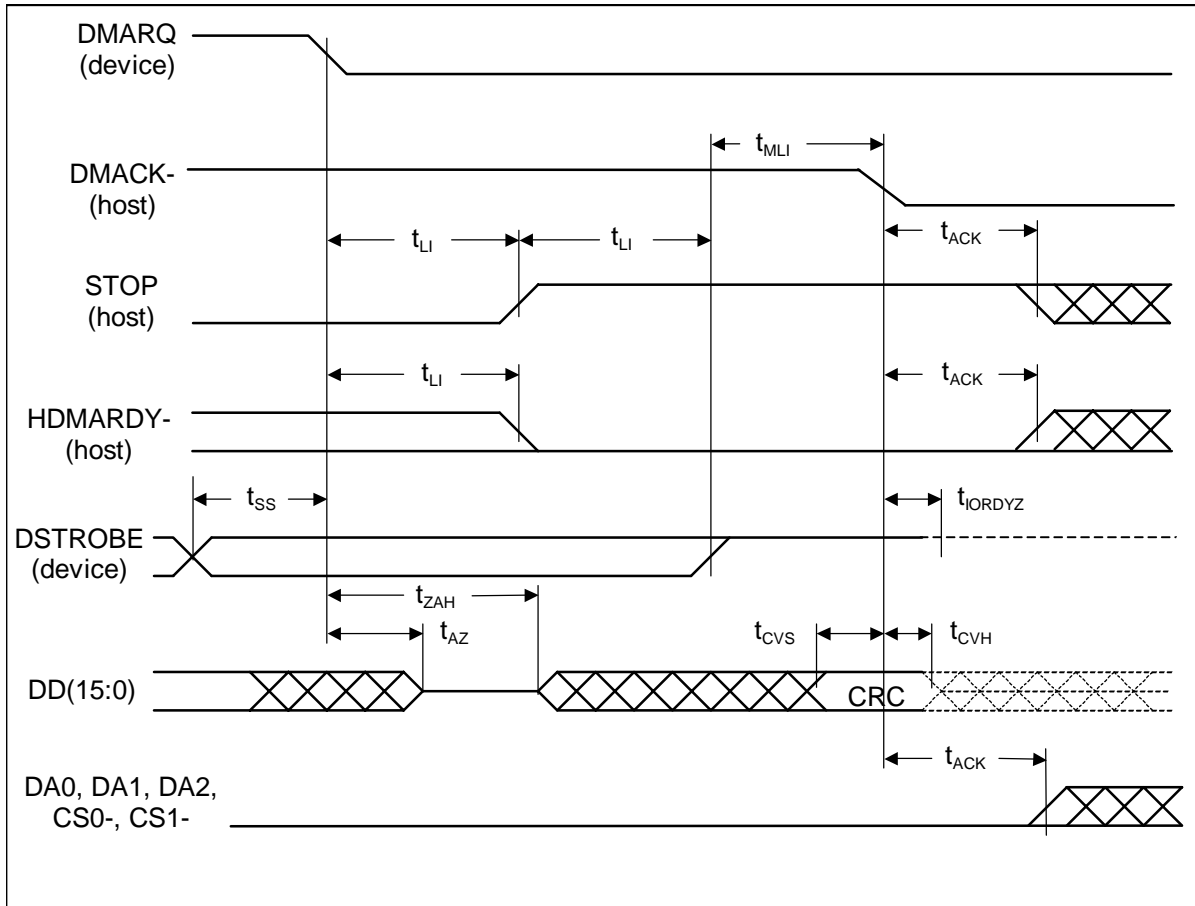

Host terminating an Ultra DMA data in burst

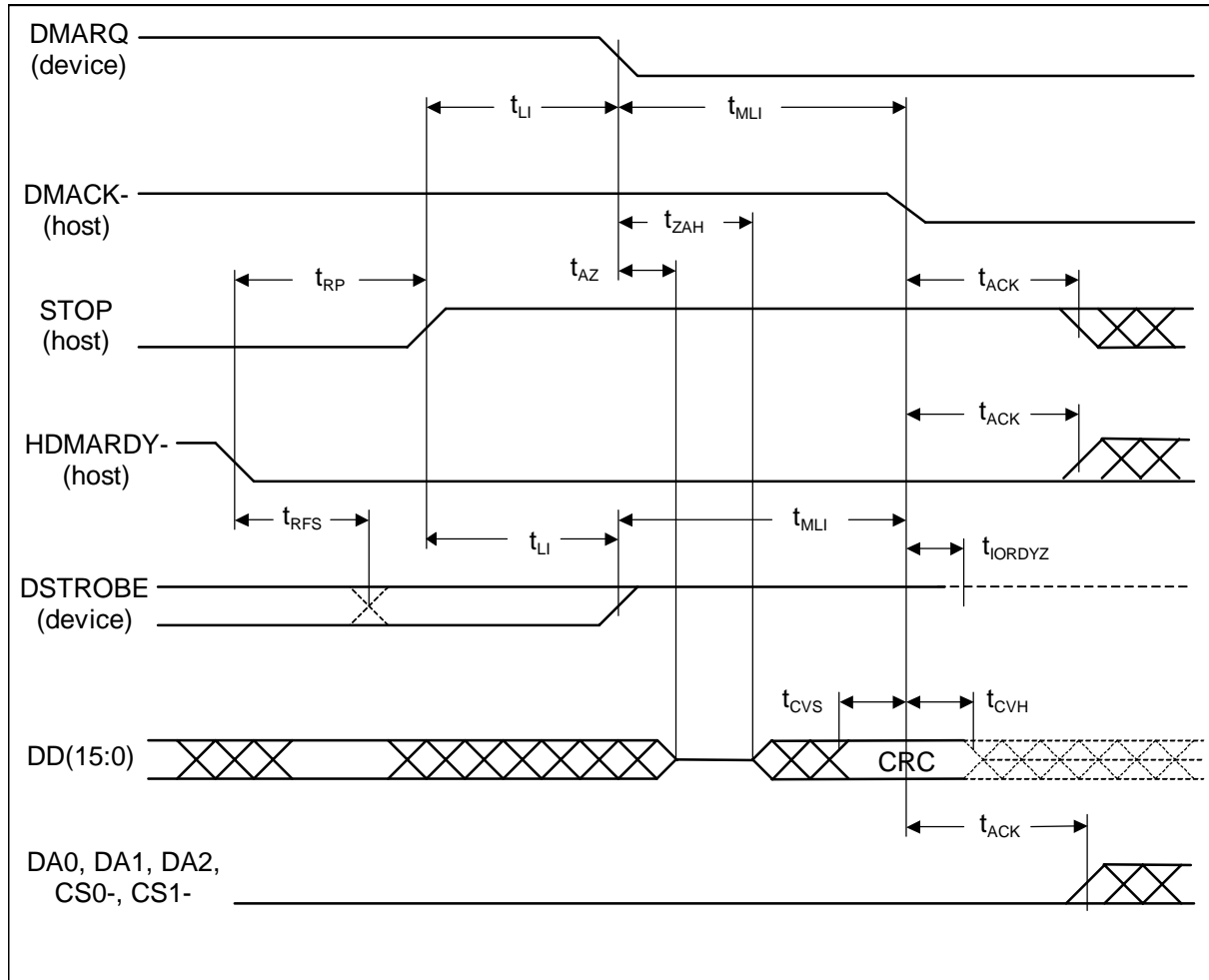

Initiating an Ultra DMA data out burst

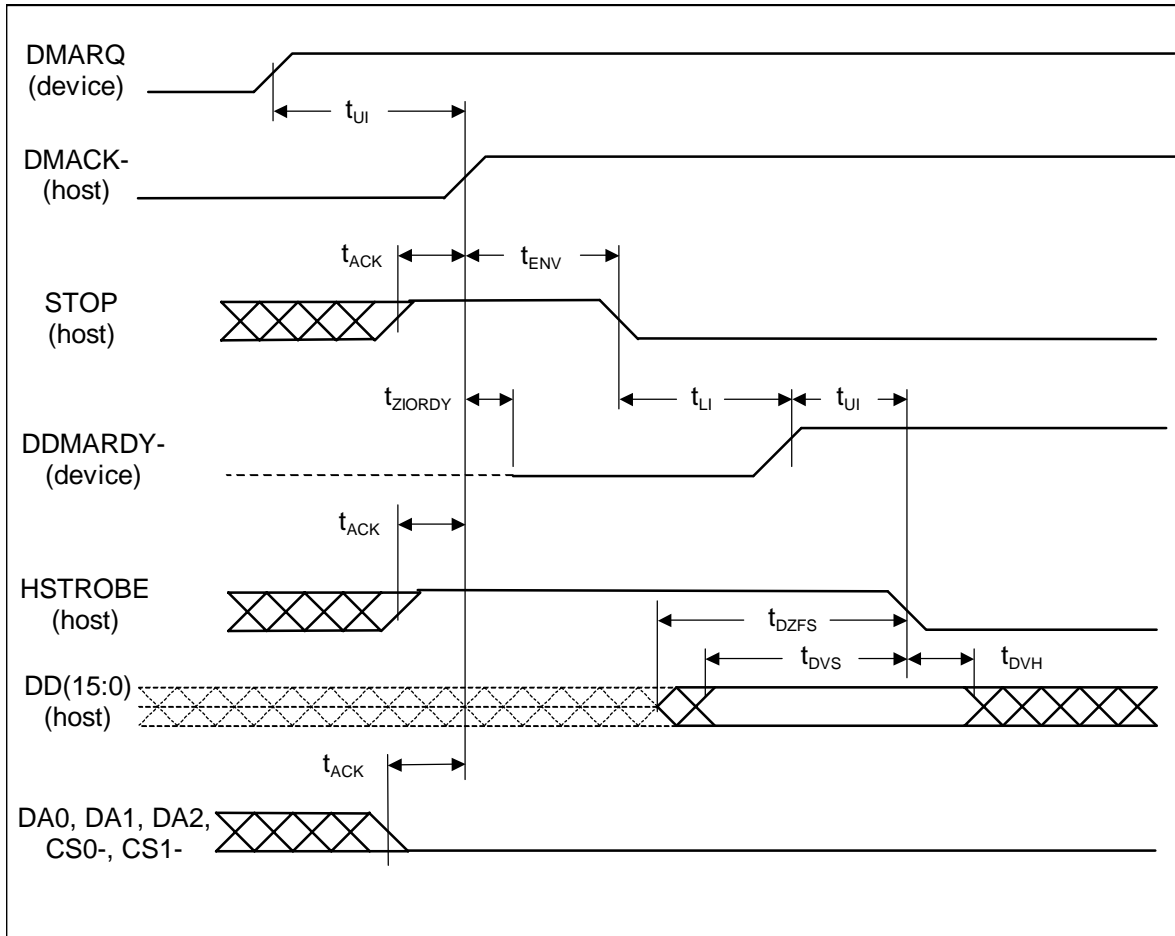

Sustained Ultra DMA data out burst

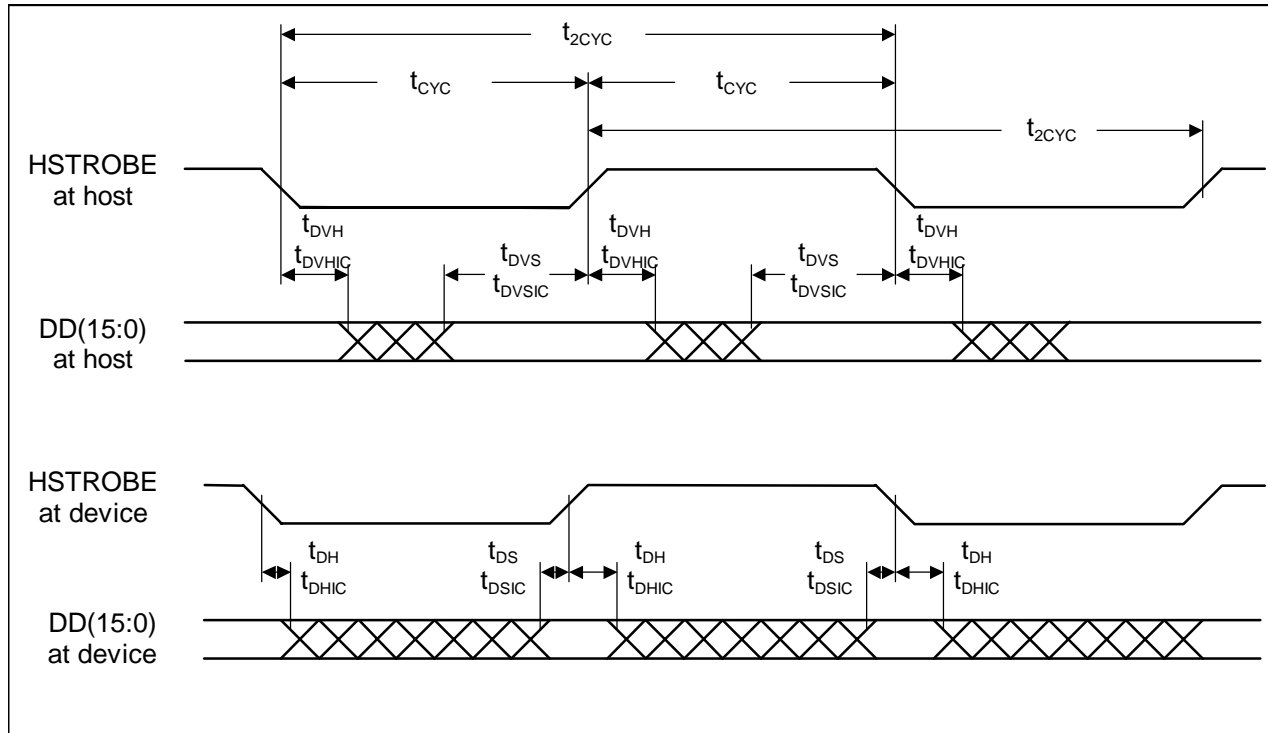

Device pausing an Ultra DMA data out burst

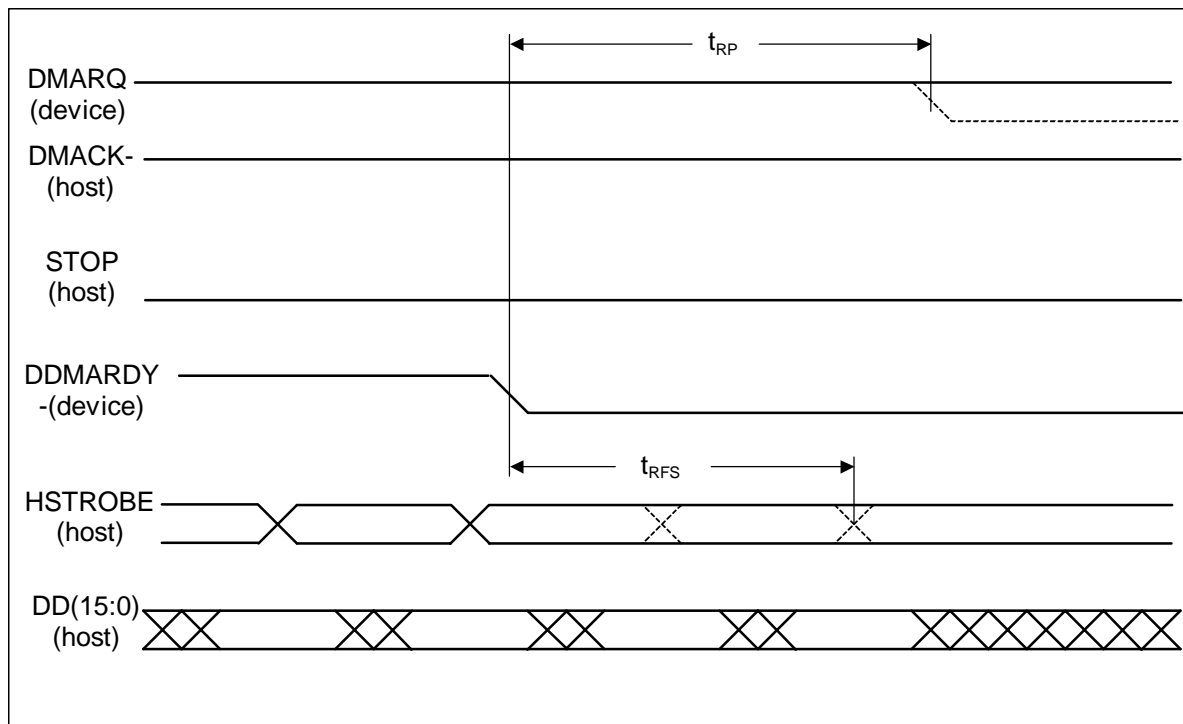

Host terminating an Ultra DMA data out burst

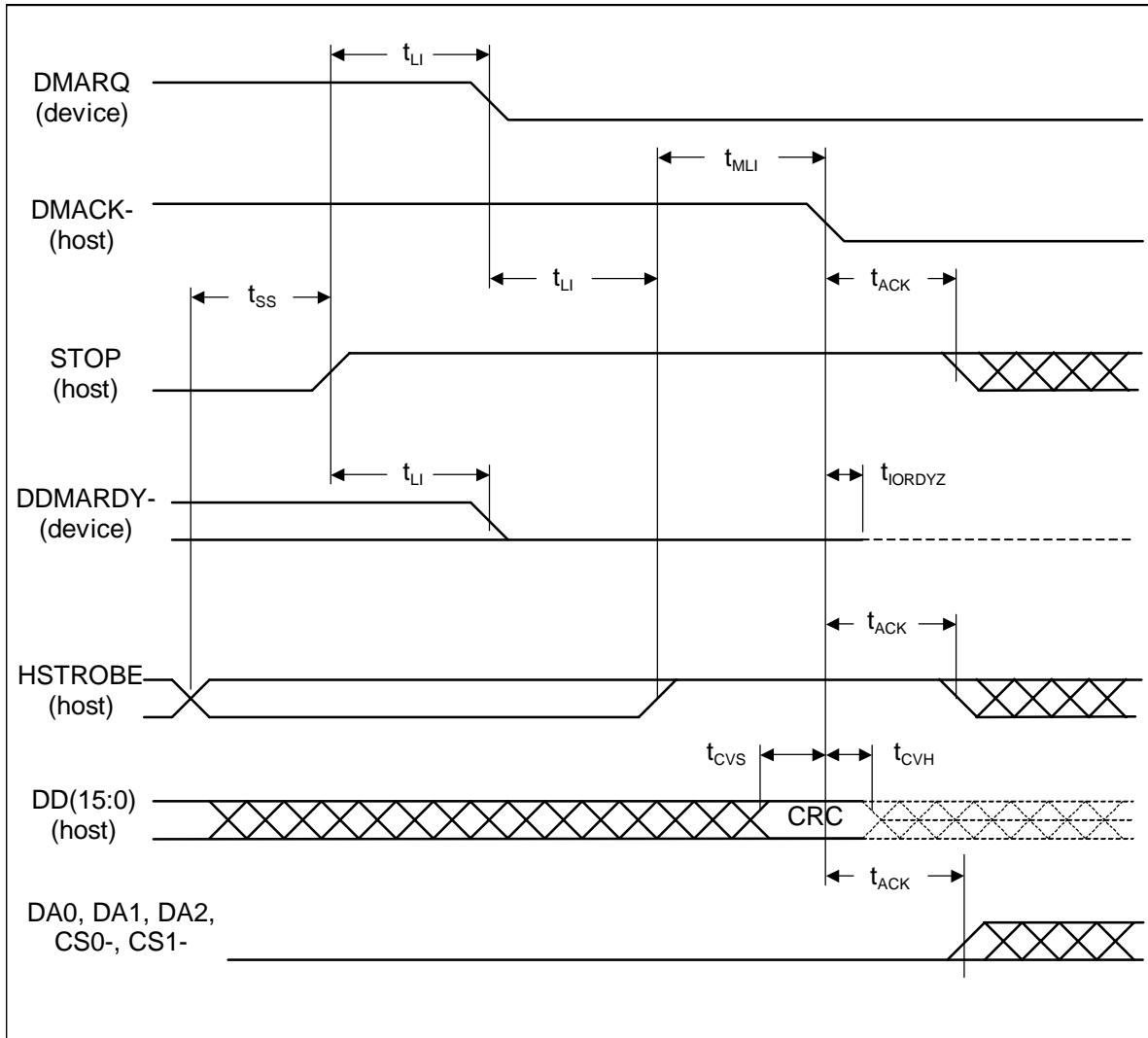

Device terminating an Ultra DMA data out burst

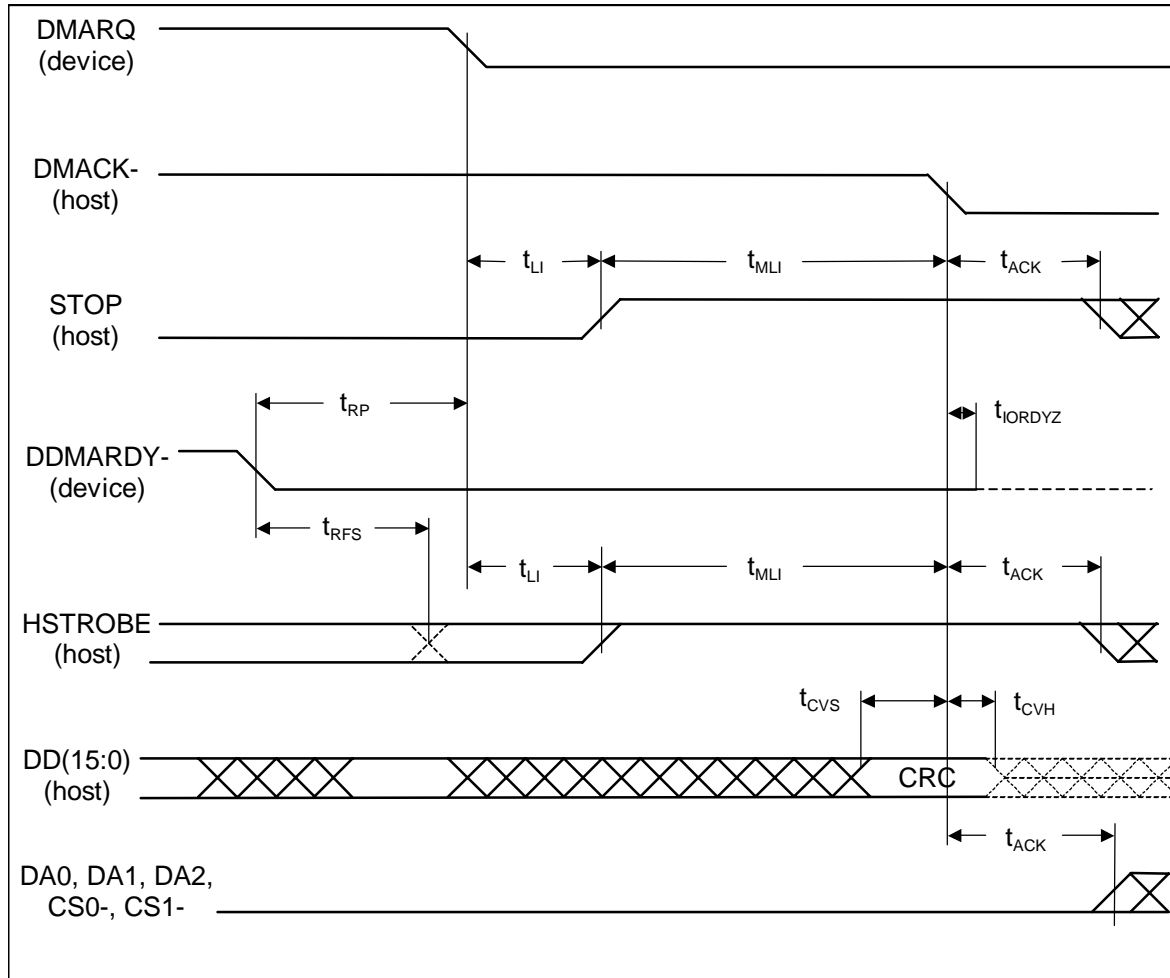

ATA/ATAPI specifications

Transfer mode		MODE 0		MODE 1		MODE 2		MODE 3		MODE 4		MODE 5	
Symbo	Meaning	Min.	Max.	Min.	Max.	Min.	Max.	Min.	Max.	Min.	Max.	Min.	Max.
1													
t_{CYC}	Cycle time	112		73		54		39		25		16.8	
t_{2CYC}	Two cycle time	230		153		115		86		57		38	
t_{DS}	Data setup time	15.0		10.0		7.0		7.0		5.0		4.0	
t_{DH}	Data hold time	5.0		5.0		5.0		5.0		5.0		4.6	
t_{DVS}	Data valid setup time	70.0		48.0		31.0		20.0		6.7		4.8	
t_{DVH}	Data valid hold time	6.2		6.2		6.2		6.2		6.2		4.8	
t_{CS}	CRC setup time	15.0		10.0		7.0		7.0		5.0		5.0	
t_{CH}	CRC hold time	5.0		5.0		5.0		5.0		5.0		5.0	
t_{CVS}	CRC valid setup time	70.0		48.0		31.0		20.0		6.7		10.0	
t_{CVH}	CRC valid hold time	6.2		6.2		6.2		6.2		6.2		10.0	
t_{ZFS}	Strobe released to driving	0		0		0		0		0		35	
t_{DZFS}	Data released to driving	70.0		48.0		31.0		20.0		6.7		25	
t_{FS}	First STROBE time	0	230	0	200	0	170	0	130	0	120	0	90
t_{LI}	Limit interlock time	0	150	0	150	0	150	0	100	0	100	0	75
t_{MLI}	Interlock time min.	20		20		20		20		20		20	
t_{UI}	Unlimited interlock	0		0		0		0		0		0	
t_{AZ}	Allowed to release		10		10		10		10		10		10
t_{ZAH}	Delay time	20		20		20		20		20		20	
t_{ZAD}	Delay time	0		0		0		0		0		0	
t_{ENV}	Envelope time	20	70	20	70	20	70	20	55	20	55	20	50
t_{RFS}	Ready to final Strobe		75		70		60		60		60		50
t_{RP}	Ready to pause	160		125		100		100		100		85	
t_{IORDYZ}	Pullup before IORDY		20		20		20		20		20		20
t_{ZIORDY}	Wait before IORDY	0		0		0		0		0		0	
t_{ACK}	Setup hold for DACK	20		20		20		20		20		20	
t_{SS}	Strobe to DREQ/Stop	50		50		50		50		50		50	

11.4.6 Reset Timing

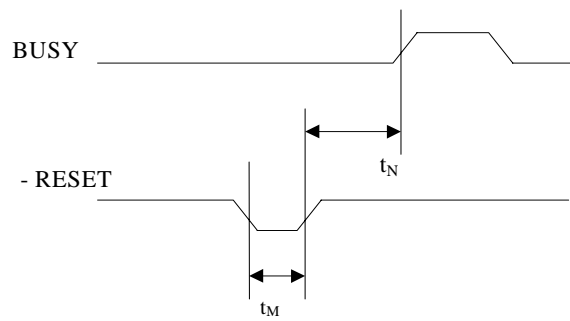

Symbol	Meaning	Minimum	Maximum	Unit	Condition
t_M	RESET pulse width (Low)	25		μs	
t_N	RESET inactive to BSY active		400	ns	

11.5 Grounding

HDA (Head Disk Assembly) and DC ground(ground pins on interface) are connected electrically each other.

11.6 Address Decoding

The host addresses the drive using programmed I/O. In this method, the required register address should be placed on the three host address lines, DA2 - DA0. An appropriate chip is selected and a read or write strode (-DIOR / -DIOW) shall be given to the chip.

The following I/O map shows definitions of all the register addresses and functions for these I/O locations. The descriptions of each register are shown in the next paragraph.

Table 11.6-1 Register map

Address					READ REGISTER	WRITE REGISTER
- CS0	- CS1	HA2	HA1	HA0		
0	0	X	X	X	Invalid address	Invalid address
0	1	0	0	0	Data register	Data register
0	1	0	0	1	Error register	Features (Write precompensation) register
0	1	0	1	0	Sector count	Sector count
0	1	0	1	1	Sector number / LBA bit 0- 7	Sector number / LBA bit0-7
0	1	1	0	0	Cylinder low / LBA bit 8- 15	Cylinder low / LBA bit8-15
0	1	1	0	1	Cylinder high / LBA bit16- 23	Cylinder high / LBA bit16-23
0	1	1	1	0	Device head register / LBA bit 24- 27	Device head register / LBA bit 24-27
0	1	1	1	1	Status register	Command register
1	0	0	X	X	High impedance	Not used
1	0	1	0	X	High impedance	Not used
1	0	1	1	0	Alt. status register	Device control register
1	0	1	1	1	Device address register ¹	Not used
1	1	X	X	X	High impedance	Not used

"X" means "don't care".

The host generates selection of two independent chips on the interface. The selected high order chip, -HOST CS1, is valid only when the host is accessing the address of alternate status register, digital output register, and digital input register respectively. The low order chip, HOST CS0, is used to address all other registers.

The following table shows the standard decode logic to connect with ISA (Industry Standard Architecture) bus.

Table 11.6-2 Decode Logic

Register Address Map	Decode
1F0-1F7	- CS0 = - ((- A9) (-A3)*(- AEN))
3F6,3F7	- CS1 = - (A9*A8*A7*A6*A5*A4*A3*A2*A1*A0)*(-A3)*(-AEN)
170-177	- CS0 = - ((- A9)*A8*(- A7)*A6*A5*A4*(- A3)*(- AEN))
376,377	- CS1 = - (A9*A8*(- A7)*A6*A5*A4)*(- A3)*(- AEN)

The host data buses 15-8 are valid only when - IOCS16 is active.

- IOCS16 is asserted when interface address lines match to data register address.

¹ ATA-2 Notes: This register is obsolete. A device is not supposed to respond to a read of this address. If a device does respond, it shall be sure not to drive the DD7 signal to prevent possible conflict with floppy disk implementations. The drive supports this register to maintain compatibility for ATA-1.

11.7 Register Description

In the following register descriptions, unused write bit should be treated as “don't care”, and unused read bits should be read as zeros.

11.7.1 Data Register

- CS0	DA2-DA0 : 0	Read / Write
-------	-------------	--------------

There are seven commands which execute data transfer from/to this register of the sector buffer for Read and Write operations. The sector table during Format command and the data associated with the Identify Device command shall also be transferred to this register.

11.7.1.1 Read/Write command

The register provides a high speed 16 bit path into the sector buffer with PIO and DMA.

11.7.1.2 Read/Write Buffer command

This command provides 16 bit path between host and data buffer in the drive.

11.7.1.3 Format command

This command provides a path for the parameter including interleave table in a sector length.

11.7.1.4 Identify Device command

Drive information is transferred during the execution of this command.

11.7.1.5 Security commands

Password information is transferred during the execution of following four commands.

- 1) Disable password
- 2) Erase Unit
- 3) Set Password
- 4) Unlock

Data in the register and on the media correspond to each other as follows:

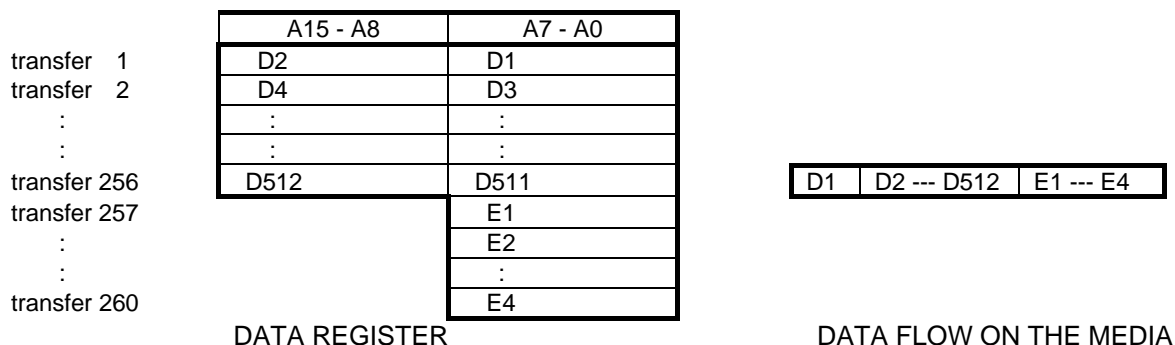

11.7.2 Error Register

- CS0	DA2-DA0 : 1	Read ONLY
-------	-------------	-----------

11.7.2.1 Operational Mode

The following descriptions are bit definitions for the operational mode including the error information from the last command. This command is valid only when the ERROR BIT (bit 0) is set.

ICRC	UNC	MC	IDNF	MCR	ABRT	TK0NF	AMNF
------	-----	----	------	-----	------	-------	------

Bit 7	Interface CRC error was found during the transfer of Ultra DMA. ²
Bit 6	UNC (Uncorrectable Data Error) -- This bit indicates that an uncorrectable error has been encountered in the data field during a read command.
Bit 5	MC (Media Changed) -- This bit is reserved for use by removable media devices and indicates that new media is available to the operating system.
Bit 4	IDNF (ID Not Found) --The requested sector could not be found.
Bit 3	MCR (Media Change Requested) is reserved for use by removable media devices and indicates that a request for media removal has been detected by the device.
Bit 2	ABRT (Aborted Command) -- This bit Indicates that the requested command has been aborted due to the reason reported in the drive status register (Write Fault, Not Seek Complete, Drive Not Ready, or an invalid command). The status registers and the error registers may be decoded to identify the cause.
Bit 1	TK0NF (Track 0 Not Found) -- This bit is set to indicate that the track 000 has not been found during a Recalibrate command.
Bit 0	AMNF (AM Not Found) -- This bit is set to indicate that the required Data AM pattern on read operation has not been found.

11.7.2.2 Diagnostic Mode

The drive enters diagnostic mode immediately after the power -on or after an Execute Diagnostics command. Error bit in Status Register shall not be set in these cases. The following table shows bit values for the diagnostic mode.

Table 11.7-1 Diagnostic mode error register

01	No errors
02	Controller register error
03	Buffer RAM error
04	ECC device error
05	CPU ROM/RAM error
06-7F	Reserved
8x	Drive1 error (see below)

When two drives are daisy-chained on the interface, the Drive0 has valid error information for diagnostic mode. When the Drive1 detects an error, 80H and OR value (01 ~ 04) diagnosed by the Drive0 are set to the code above mentioned.

11.7.3 Features Register (Write Precompensation Register)

- CS0	DA2-DA0 : 1	Write only
-------	-------------	------------

Write precompensation is automatically optimized by the drive internally. This register is used with Set Features command.

² ATA-2 Notes: Prior to the development of ATA-2 standard, this bit was defined as BBK (Bad Block Detected) -- This bit was used to indicate that the block mark was detected in the target's ID field. The mark does not exist when shipping from the factory. The Mark will be written by FORMAT command. Read or Write commands will not be executed in any data fields marked bad. The drive does not support this bit.

11.7.3.1 *Smart command*

This command is used with the Smart commands to select subcommands.

11.7.4 Sector Count Register

- CS0	DA2-DA0 : 2	Read / Write
-------	-------------	--------------

11.7.4.1 *Disk Access command*

The sector count register determines the number of sectors to be read or written for Read, Write, and Verify commands. A 0 in the sector count register specifies a 256 sector transfer. After normal completion of a command, the content shall be 0.

During a multi-sector operation, the sector count is decremented and the sector number is incremented. If an error should occur during multi-sector operation, this command shows the number of remaining sectors in order to avoid duplicated transfer.

11.7.4.2 *Initialize Device Parameters command*

This register determines number of sectors per track.

11.7.4.3 *Power Control command*

This register returns a value in accordance with the operation mode (idle mode or stand-by mode).

11.7.4.4 *Set Features Command*

If features register for this command is 03h, this register sets the data transfer mode.

11.7.5 Sector Number Register

- CS0	DA2-DA0 : 3	Read / Write
-------	-------------	--------------

The target logical sector number (starting from 1) for Read, Write, and Verify commands is set in this register. After completion of a command, it shows the sector number of the last sector transferred to the host.

The starting sector number is set in this register for multi-sector operations. But when error occurs during multi-sector transfer, it shows the number of the sector in which the error has been detected. During multi-sector transfer, the number of the next sector to be transferred will not necessarily be shown.

In LBA mode, this register contains Bits 0 - 7 logical block address. After completion of a command, the register is updated to reflect the current LBA Bits.

11.7.6 Cylinder Low Registers

- CS0	DA2-DA0 : 4	Read / Write
-------	-------------	--------------

11.7.6.1 Disk Access command

Lower 8 bits of the starting cylinder number (starting from 0) for Read, Write, Seek, and Verify commands are contained in these registers. After completion of the command or sector transfer, the current cylinder is shown in this register.

In LBA mode, Bits 8 - 15 of the target address in logical block address are set in this register. After completion of a command, the register is updated to reflect the current LBA Bits 0 - 7.

11.7.6.2 SMART commands

This register should be set to 4Fh for SMART commands

11.7.7 Cylinder High Registers

- CS0	DA2-DA0 : 5	Read / Write
-------	-------------	--------------

11.7.7.1 Disk Access command

The high order bits of the starting cylinder number (starting from 0) for Read, Write, Seek, and Verify commands are set in this register. After completion of the command or sector transfer, the current cylinder is shown in this register.

In LBA mode, Bits 16 - 23 of the target address in logical block address are contained in this register. After completion of the command, it shows the Bits 0 - 7 of the last logical block address.

	Cylinder High	Cylinder Low
Register Bits	7 6 5 4 3 2 1 0	7 6 5 4 3 2 1 0
Cylinder Bits	15 14 13 12 11 10 9 8	7 6 5 4 3 2 1 0

11.7.7.2 SMART commands

This register should be set to C2h for SMART commands

11.7.8 Device/Head Register

- CS0	DA2-DA0 : 6	Read / Write
-------	-------------	--------------

The value of this register is used to select the drive, Drive0 or Drive1, and head. On multiple sector read/write operation that requires to cross track boundaries, the head select bit will be updated to reflect the currently selected head number.

1	L	1	DEV	HS3	HS2	HS1	HS0
---	---	---	-----	-----	-----	-----	-----

Bit 7	Reserved (recommended to set 1)
Bit 6	L (Select LBA mode) L=0: CHS mode. L=1: LBA mode.
Bit 5	Reserved (recommended to set 1)
Bit 4	DEV (Device Select): - (Drive0/Drive1 mode) This bit is used to select the drive. DEV= 0 indicates the first fixed disk drive (Drive0), and DEV= 1 indicates the second (Drive1). - (Single mode) should be 0. If this is 1, a drive is not selected but 00h shall be returned to status register.
Bit 3 - Bit 0	HS3-HS0 (Head Select Bits) -- Bits 3 through 0 determine the required read/write head. Bit 0 is the least-significant bit. If the L bit is equal to one (LBA Mode), the HS3 through HS0 bits contain bits 27 through 24 of the LBA.

11.7.9 Status Register

-CS0	DA2-DA0:7	Read only
------	-----------	-----------

This register contains the command status. The contents of the register are updated at the completion of each command and whenever the error occurs. The host system reads this register in order to acknowledge the status and the result of each operation.

When the BSY bit (bit 7) is set, no other bits in the register are valid. And read/write operations of any other register are negated in order to avoid the returning of the contents of this register instead of the other registers' contents .

If the host reads this register when an interrupt is pending, interrupt request (INTRQ) is cleared in order to work as Interrupt Acknowledge.

The bits of the status register are defined as below :

BSY	DRDY	DF	DSC ³	DRQ	CORR	IDX	ERR
-----	------	----	------------------	-----	------	-----	-----

Bit 7	BSY (Busy) -- This bit is set when Host Reset (HRST) line is activated or Software Reset (SRST) bit in Device Control register is set or when the COMMAND register is written and until a command is completed but when Data Request is set to 1, this bit shall be reset. The host shouldn't write or read any registers when BSY = 1.
Bit 6	DRDY (Drive ready) -- DRDY=1 when seek complete bit (bit 4) = 1, indicates that the drive is ready to respond read, write, or seek command. DRDY=0 indicates that read , write and seek are negated. A command execution shall be interrupted if Not-Ready condition occurs during a command execution and will be reset until the next command whether the drive condition is Ready or Not Ready. Error bit is set on this occasion and will be reset just after power on and set again after the drive begins revolving at normal speed and gets ready to receive a command.
Bit 5	DF (Device Fault) -- DF=1 indicates that the drive has detected a fault condition during the execution of a Read Write commands; read, write, and seek commands are negated and Error bit is set. DF is set to 1 until the next command, whether the device is in fault condition or not.
Bit 4	DSC³ (Drive Seek Complete) – DSC ³ = 1 indicates that a seek operation has been completed. DSC ³ is set to 0 when a command accompanied by a seek operation begins. If a seek is not complete, a command is terminated and this bit is not changed until the Status Register is read by the host . This bit remains reset immediately after power on until the drive starts revolving at a nominal speed and gets ready to receive command.
Bit 3	DRQ (Data Request) -- DRQ=1 indicates that the sector buffer requires 1 sector of data during a Read or Write command.
Bit 2	CORR (Corrected Data) -- CORR=1 indicates that the data read from the disk had an error but was successfully corrected by the read retry. This bit is always set to 0 and does not interrupt multi-sector operations.
Bit 1	IDX (Index) -- This bit is a pulse signal set to 1 per revolution of the disk. Intervals of the signal may vary during read / write operation. Therefore, the host shouldn't use IDX for timing purposes.
Bit 0	ERR (Error) -- ERR = 1 indicates that an error occurred during execution of the previous command . The cause of the error is reported on the other bit or in the error register. The error bit can be reset by the next command from the controller. When this bit is set , a multi-sector operation is negated.

³ ATA-2 Notes: Prior to ATA-2 standard, this bit indicated that the device was on track. This bit may be used for other purposes in future standards. For compatibility the drive supports this bit as ATA-1 specifies. User is recommended not to use this bit.

11.7.10 Command Register

- CS0	DA2-DA0 : 7	Write only
-------	-------------	------------

The command register accepts commands for the drive to perform fixed disk operations. Commands are executed when the TASK FILE is loaded and the command register is written and only when:

The status is not busy (BSY is inactive).
and
DRDY (drive ready) is active.

Any code NOT defined in the following list causes an Aborted Command error. Interrupt request (INTRQ) is reset when a command is written. The following are acceptable commands to the command register.

Table 11.7-2 Command Code

Command Code								
Command Name		Hex Value	PARAMETERS USED					
			SC	SN	CY	DRV	HD	FT
Nop		00H	X	X	X	O	X	X
Recalibrate		1xH	X	X	X	O	X	X
Read Sector(s)		20/21H	O	O	O	O	O	X
Read Sector(s) EXT		24h	O	O	O	O	O	X
Read DMA EXT		25H	O	O	O	O	O	X
Read Native Max Address EXT		27H	X	X	X	O	X	X
Read Multiple EXT		29H	O	O	O	O	O	X
Write Sector(s)		30/31H	O	O	O	O	O	X
Write Sector(s) EXT		34H	O	O	O	O	O	X
Write DMA EXT		35H	O	O	O	O	O	X
Set Max Address EXT		37H	O	O	O	O	O	X
Write Multiple EXT		39H	O	O	O	O	O	X
Write Verify		3CH	O	O	O	O	O	X
Read Verify Sector(s)		40/41H	O	O	O	O	O	X
Read Verify Sector(s) EXT		42H	O	O	O	O	O	X
Format Track		50H	X	X	O	O	O	X
Seek		7xH	X	X	O	O	O	X
Execute Diagnostics		90H	X	X	X	O	X	X
Initialize Device Parameters		91H	O	X	X	O	O	X
Download Microcode		92H	O	O	X	O	X	O
SMART		B0H	X	X	O	O	X	O
Device Configuration		B1H	X	X	X	O	X	O
Read Multiple		C4H	O	O	O	O	O	X
Write Multiple		C5H	O	O	O	O	O	X
Set Multiple Mode		C6H	O	X	X	O	X	X
Read DMA		C8/C9H	O	O	O	O	O	X
Write DMA		CA/CBH	O	O	O	O	O	X
Power Control	Stand-by Immediate	E0 / 94H	O	X	X	O	X	X
	Idle Immediate	E1 / 95H	O	X	X	O	X	X
	Stand-by	E2 / 96H	O	X	X	O	X	X
	Idle	E3 / 97H	O	X	X	O	X	X
	Check Power Mode	E5 / 98H	O	X	X	O	X	X
	Sleep	E6 / 99H	O	X	X	O	X	X
Read Buffer		E4H	X	X	X	O	X	X
Flush Cache		E7H	X	X	X	O	X	X
Write Buffer		E8H	X	X	X	O	X	X
Flush Cache EXT		EAH	X	X	X	O	X	X
Identify Device		ECH	X	X	X	O	X	X
Set Features		EFH	X	X	X	O	X	O
Security	Set Password	F1H	X	X	X	O	X	X
	Unlock	F2H	X	X	X	O	X	X
	Erase Prepare	F3H	X	X	X	O	X	X
	Erase Unit	F4H	X	X	X	O	X	X
	Freeze	F5H	X	X	X	O	X	X
	Disable Password	F6H	X	X	X	O	X	X
Read Native Max Address		F8H	X	X	X	O	X	X
Set Max		F9H	O	O	O	O	O	X
Read Sence Data		FCH	X	X	X	O	X	O

Note: O and X are defined as follows.

O = Must contain valid information for this command.

X = Don't care for this command.

Parameters are defined as follows.

SC = SECTOR COUNT register.

SN = SECTOR NUMBER register.

CY = CYLINDER LOW and CYLINDER HIGH register.

DRV = DRIVE SELECT bit (bit 4 in DRIVE/HEAD register)

HD = HEAD SELECT bits (bit 3-0 in DRIVE/HEAD register)

FT = FEATURES register (WRITE PRECOMPENSATION register)

11.7.11 Alternate Status Register

- CS1	DA2-DA0 : 6	Read only
-------	-------------	-----------

This register contains the same information as the status register in the Task File. The only difference is that this register being read does not imply interrupt acknowledge or doesn't reset a pending interrupt.

See the description of " status resister " for definitions of the bit in this register.

11.7.12 Device Control Register

- CS1	DA2-DA0 : 6	Write only
-------	-------------	------------

This register contains the following three control bits.

HOB	----	----	----	1	SRST	- IEN	----
-----	------	------	------	---	------	-------	------

Bit 7	HOB (High Order Byte) is defined by the 48-bit Address feature set. A write to any Command register shall clear the HOB bit to zero.
Bit 6-4	not used
Bit 3	Reserved (recommended to set 1)
Bit 2	SRST (Soft Reset) -- SRST= 1 indicates that the drive is held reset and sets BSY bit in Status register. All internal registers are reset as shown in Table 11.12-1 . If two drives are daisy chained on the interface, this bit will reset both drives simultaneously , regardless of the selection by Device address bit in DEVICE/HEAD register.
Bit 1	- IEN (Interrupt Enable) -- When -IEN = 0, and the drive is selected by Drive select bit in DEVICE/HEAD register, the drive interrupt to the host is enabled. When this bit is set, the - INTRQ pin will be in a high impedance state, whether a pending interrupt is found or not.
Bit 0	not used

11.7.13 Device Address register⁴

- CS1	DA2-DA0 : 7	read only
-------	-------------	-----------

The device address register is a read-only register used for diagnostic purposes. The followings are definitions of bits for this register:

RSVD	- WTG	- HS3	- HS2	- HS1	- HS0	- DS1	- DS0
------	-------	-------	-------	-------	-------	-------	-------

Bit 7	Reserved -- high impedance
Bit 6	- WTG (Write Gate) -- This bit is active when a Write to the disk is in progress.
Bit 5 - Bit 2	- HS3 to - HS0 (Head Select bits) -- Bit 5 through 2 are one's complement of the binary coded address of currently selected head which is shown by Head Select bit in SDH register.
Bit 1	- DS1 (Drive Select 1) -- -DS1=0, when Drive1 is selected and active.
Bit 0	- DS0 (Drive Select 0) -- -DS0=0, when single mode or Drive0 in Drive0/Drive1 mode is selected and active.

Note) The following facts should be taken into consideration when this register is in use.

-WG reflects actual write gate in the drive, however, because of address transition or cache operation, there is no direct connection with the data transferred between host and drive.

⁴ ATA-2 Notes: This register is obsolete. A device is not supposed to respond to a read of this address. If a device does respond, it shall be sure not to drive the DD7 signal to prevent possible conflict with floppy disk implementations. The drive supports this register to maintain compatibility for ATA-1.

-HEAD SELECT represents one's complement of the binary coded address of currently selected head, but does not show actual selection of the head.

11.8 Command Descriptions

The drive interprets the commands written in the command register by the host system and executes them. This table shows the drive's response to the valid commands written in command-register.

Command	Status register				Error register					
	DRDY	DF	CORR	ERR	ICRC	UNC	IDNF	ABRT	TKONF	AMNF
CHECK POWER MODE	√	√		√				√		
EXECUTE DEVICE DIAGNOSTIC	√	√		√	See Table 11.7-1					
DEVICE CONFIGRATION RESTORE	√	√		√				√		
DEVICE CONFIGRATION FRESZE LOCK	√	√		√				√		
DEVICE CONFIGRATION IDENTIFY	√	√		√				√		
DEVICE CONFIGRATION SET	√	√		√				√		
DOWNLOAD MICROCODE	√	√		√				√		
FLUSH CACHE (EXT)	√	√		√			√	√		
FORMAT TRACK	√	√		√		√	√	√	√	√
IDENTIFY DEVICE	√	√		√				√		
IDLE	√	√		√				√		
IDLE IMMEDIATE	√	√		√				√		
INITIALIZE DEVICE PARAMETERS	√	√								
READ BUFFER	√	√		√				√		
READ DMA (EXT)	√	√		√	√	√	√	√		√
READ MULTIPLE (EXT)	√	√		√		√	√	√		√
READ NATIVE MAX ADDRESS (EXT)	√			√						
READ SECTOR(S) (EXT)	√	√		√		√	√	√		√
READ VERIFY SECTOR(S) (EXT)	√	√		√		√	√	√		√
RECALIBRATE	√	√		√				√	√	
SECURITY DISABLE PASSWORD	√	√		√				√	√	
SECURITY ERASE PREPARE	√	√		√				√	√	
SECURITY ERASE UNIT	√	√		√				√	√	
SECURITY FREEZE LOCK	√	√		√				√	√	
SECURITY SET PASSWORD	√	√		√				√	√	
SECURITY UNLOCK	√	√		√				√	√	
SEEK	√	√		√			√	√		
SET FEATURES	√	√		√				√		
SET MAX ADDRESS (EXT)	√			√			√	√		
SET MAX SET PASSWORD	√			√				√		
SET MAX LOCK	√			√				√		
SET MAX UNLOCK	√			√				√		
SET MAX FLEEZE LOCK	√			√				√		
SET MULTIPLE MODE	√	√		√				√		
SLEEP	√	√		√				√		
SMART Enable/Disable Attribute autosave	√	√		√				√		
SMART Enable/Disable Automatic Off-line	√	√		√				√		
SMART DISABLE OPERATIONS	√	√		√				√		
SMART ENABLE OPERATIONS	√	√		√				√		
SMART RETURN STATUS	√	√		√				√		
SMART Read Attribute Values	√	√		√		√	√	√		
SMART Read Attribute Thresholds	√	√		√				√		
SMART Save Attribute Values	√	√		√				√		
SMART Execute OFF-LINE Immediate	√	√		√			√	√		
SMART Read Log Sector	√	√		√		√	√	√		
SMART Write Log Sector	√	√		√			√	√		
STANDBY	√	√		√				√		
STANDBY IMMEDIATE	√	√		√				√		
WRITE BUFFER	√	√		√				√		
WRITE DMA (EXT)	√	√		√	√		√	√		
WRITE MULTIPLE (EXT)	√	√		√			√	√		
WRITE SECTOR(S) (EXT)	√	√		√			√	√		
WRITE VERIFY	√	√		√			√	√		
Invalid command code	√	√		√				√		

√ = valid on this command

11.8.1 Nop (00h)

COMMAND CODE		0 0 0 0 0 0 0 0	REGISTER
REGISTER SETTING			NORMAL COMPLETION
DR	drive no.		no change
CY			no change
HD			no change
SN			no change
SC			no change
FT			no change
LBA			no change

The Nop command reports the status. The drive terminates the command with aborted error after receiving this command.

11.8.2 Recalibrate⁵ (1xh)

COMMAND CODE		0 0 0 1 X X X X	REGISTER
REGISTER SETTING			NORMAL COMPLETION
DR	drive no.		no change
CY			00H
HD			no change
SN			no change
SC			no change
FT			no change
LBA			00H

This command will set BSY bit and move the R/W heads on the disk to cylinder 0. At the completion of a seek , it revises the status, resets BSY and generates an interrupt.

11.8.3 Flush Cache (E7h)

COMMAND CODE		1 1 1 0 0 1 1 1
REGISTER SETTING	DR	drive no.

This command reports the completion of a Write cache to the host. At the completion of a Write cache, the drive revises the status, resets BSY and generates an interrupt.

11.8.4 Flush Cache EXT (EAh)

COMMAND CODE		1 1 1 0 1 0 1 0
REGISTER SETTING	DR	drive no.

This command reports the completion of a Write cache to the host. At the completion of a Write cache, the drive revises the status, resets BSY and generates an interrupt.

⁵ ATA/ATAPI-4 defines this command as Vendor specific. The drive supports this command to maintain ATA-3, and the previous models compatibility. User is recommended not to use this command.

11.8.5 Read Sector (20h/21h)

COMMAND CODE		0 0 1 0 0 0 0 X	REGISTER
		REGISTER SETTING	NORMAL COMPLETION
DR		drive no.	no change
CY		starting cylinder	last possible
HD		starting head	last possible
SN		starting sector	last possible
SC		no. of sector to read	00H
FT			no change
LBA		starting address	last address

Setting BSY bit, the drive will seek to the target cylinder if the head is not on target track (implied seek), select the head and begin to read the number of sector defined in SC register (1-256) starting from the target sector. After finding ID of target sector and having 1 sector of data read into the buffer RAM, the drive sets DRQ in status register and generates interrupt to report to the host that the drive is ready to transfer the next data.

In case of multi-sector transfer, DRQ bit is reset and BSY is set after 1 sector transfer to prepare for the next sector transfer.

An uncorrectable data can also be transferred but the subsequent operation will terminate at the cylinder, head, and sector (or LBA) position in the TASK FILE register. When a sector is ready to be read by the host, an interrupt is issued. After the last sector is read by the host, no interrupt is issued at the end of a command.

11.8.6 Read Sector EXT (24h)

COMMAND CODE		0 0 1 0 0 1 0 0	REGISTER
		REGISTER SETTING	NORMAL COMPLETION
DR		drive no.	no change
LBA	Current	LBA(7:0)	HOB=0 last address
Low	Previous	LBA(31:24)	HOB=1 last address
LBA	Current	LBA(15:8)	HOB=0 last address
Mid	Previous	LBA(39:32)	HOB=1 last address
LBA	Current	LBA(23:16)	HOB=0 last address
High	Previous	LBA(47:40)	HOB=1 last address
SC	Current	sector count(7:0)	HOB=0 00H
	Previous	sector count(15:8)	HOB=1 00H
FT	Current	reserved	HOB=0 no change
	Previous	reserved	HOB=1 no change

Setting BSY bit, the drive will seek to the target cylinder if the head is not on target track (implied seek), select the head and begin to read the number of sector defined in SC register (1-65536) starting from the target sector. After finding ID of target sector and having 1 sector of data read into the buffer RAM, the drive sets DRQ in status register and generates interrupt to report to the host that the drive is ready to transfer the next data.

In case of multi-sector transfer, DRQ bit is reset and BSY is set after 1 sector transfer to prepare for the next sector transfer.

An uncorrectable data can also be transferred but the subsequent operation will terminate at the LBA position in the TASK FILE register. When a sector is ready to be read by the host, an interrupt is issued. After the last sector is read by the host, no interrupt is issued at the end of a command.

This command is available in LBA addressing only.

11.8.7 Write Sector (30h/31h)

COMMAND CODE		0 0 1 1 0 0 0 X	REGISTER
REGISTER SETTING			NORMAL COMPLETION
DR		drive no.	no change
CY		starting cylinder	last possible
HD		starting head	last possible
SN		starting sector	start sector
SC		no. of sector to write	00H
FT			no change
LBA		starting address	last possible

The drive seeks to the target cylinder and selects the head and begins to write to the number of sectors defined in SC register (1-256) starting from the target sector. DRQ in status register is set as soon as the command register is written and the buffer RAM receives the data transferred from the host. After 1 sector is transferred to the buffer RAM, the drive resets DRQ, sets BSY and begins write operation. In case of multi-sector transfer, it sets DRQ bit, resets BSY and generates Interrupt to inform host that it is ready to transfer the next 1 sector of data. The drive will seek to the target cylinder if the head is not on the target track (implied seek). After transferring the last data in the buffer, it resets BSY and issues an interrupt.

If an error occurs during multi-sector transfer, it will terminate the transfer by setting error information in status register and error register, without shifting into data transfer mode from the host. CY, HD, SN (LBA) registers show the address where error has occurred.

11.8.8 Write Sector EXT (34h)

COMMAND CODE		0 0 1 1 0 1 0 0	REGISTER	
REGISTER SETTING			NORMAL COMPLETION	
DR		drive no.	no change	
LBA	Current	LBA(7:0)	HOB=0	last address
Low	Previous	LBA(31:24)	HOB=1	last address
LBA	Current	LBA(15:8)	HOB=0	last address
Mid	Previous	LBA(39:32)	HOB=1	last address
LBA	Current	LBA(23:16)	HOB=0	last address
High	Previous	LBA(47:40)	HOB=1	last address
SC	Current	sector count(7:0)	HOB=0	00H
	Previous	sector count(15:8)	HOB=1	00H
FT	Current	reserved	HOB=0	no change
	Previous	reserved	HOB=1	no change

The drive seeks to the target cylinder and selects the head and begins to write to the number of sectors defined in SC register (1-65536) starting from the target sector. DRQ in status register is set as soon as the command register is written and the buffer RAM receives the data transferred from the host. After 1 sector is transferred to the buffer RAM, the drive resets DRQ, sets BSY and begins write operation. In case of multi-sector transfer, it sets DRQ bit, resets BSY and generates Interrupt to inform host that it is ready to transfer the next 1 sector of data. The drive will seek to the target cylinder if the head is not on the target track (implied seek). After transferring the last data in the buffer, it resets BSY and issues an interrupt.

If an error occurs during multi-sector transfer, it will terminate the transfer by setting error information in status register and error register, without shifting into data transfer mode from the host. LBA registers show the address where error has occurred.

This command is available in LBA addressing only.

11.8.9 Read Verify (40h)

COMMAND CODE		0 1 0 0 0 0 0 0	REGISTER	
		REGISTER SETTING		NORMAL COMPLETION
DR		drive no.		no change
CY		starting cylinder		last possible
HD		starting head		last possible
SN		starting sector		start sector
SC		no. of sector to be read		00H
LBA		starting address		last address

This command is identical to a Read command except that the drive has read the data from the media, and the DRQ bit is not set and no data is sent to the host. This allows the system to verify the integrity of the drive. A single interrupt is generated upon completion of a command or when an error occurs.

11.8.10 Read Verify EXT (42h)

COMMAND CODE		0 1 0 0 0 0 1 0	REGISTER	
		REGISTER SETTING		NORMAL COMPLETION
DR		drive no.		no change
LBA	Current	LBA(7:0)		HOB=0 last address
Low	Previous	LBA(31:24)		HOB=1 last address
LBA	Current	LBA(15:8)		HOB=0 last address
Mid	Previous	LBA(39:32)		HOB=1 last address
LBA	Current	LBA(23:16)		HOB=0 last address
High	Previous	LBA(47:40)		HOB=1 last address
SC	Current	sector count(7:0)		HOB=0 00H
	Previous	sector count(15:8)		HOB=1 00H
FT	Current	reserved		HOB=0 no change
	Previous	reserved		HOB=1 no change

This command is identical to a Read EXT command except that the drive has read the data from the media, and the DRQ bit is not set and no data is sent to the host. This allows the system to verify the integrity of the drive. A single interrupt is generated upon completion of a command or when an error occurs.

This command is available in LBA addressing only.

11.8.11 Write Verify⁶ (3Ch)

COMMAND CODE		0 0 1 1 1 1 0 0	REGISTER
REGISTER SETTING		NORMAL COMPLETION	
DR	drive no.		no change
CY	starting cylinder		last possible
HD	starting head		last possible
SN	starting sector		start sector
SC	no. of sector to be written		00H
LBA	starting address		last address

This command is all identical to a Write sector command. Read verification is not performed in this command. A Write verify command transfers the number of sectors (1-256) defined in SC register from the host to the drive, then the data is written on the media. The starting sector is defined in CY, HD, SN (LBA) registers.

Upon receipt of the command, the drive sets DRQ until one sector of data is transferred from the host, then resets DRQ, sets BSY. In case of multi- sector transfer, it sets DRQ, resets BSY and generate an interrupt to report the host that the host is ready to receive 1 sector of data. The drive will seek to the target track if the R/W head is not on the target track (implied seek). Reaching the target sector, the command transfers the sector data from the host to the media. After transferring the last data in the buffer, it sets BSY and issues an Interrupt.

11.8.12 Format Track ⁷ (50h)

COMMAND CODE		0 1 0 1 0 0 0 0	REGISTER
REGISTER SETTING		NORMAL COMPLETION	
DR	drive no.		no change
CY	cylinder to format		no change
HD	head to format		no change
SN			01H
SC			00H
FT			no change

The track specified by the task file is formatted with ID and data fields according to the table transferred to the buffer. This command is rejected in LBA mode with an Aborted command error reported.

DRQ in status register is set as soon as the command register is written, and the buffer RAM receives the data transferred from the host. After 512 bytes are transferred into the buffer RAM, the drive resets DRQ, sets BSY and begins format operation. The drive seeks to the target cylinder if the head is not on the target track (implied seek). After completion of the command, it resets BSY and generates an interrupt.

Format table consists of the number of sectors (16 bits) per track . Upper byte represents sector number, and lower byte represents format type.

The drive supports only 00H format type. Intending to maintain compatibility with previous models, the drive accepts any format type, but the function will not change.

⁶ ATA/ATAPI-4 defines this command as Vendor specific. The drive supports this command to maintain ATA-3 compatibility. User is recommended not to use this command.

⁷ ATA/ATAPI-4 defines this command as Vendor specific. The drive supports this command to maintain ATA-3, and the previous models compatibility. User is recommended not to use this command.

Sector interleave is always set to one regardless of sector sequence in the format table. Data subsequent to format table are handled as "Don't care".

FORMAT TABLE (FIRST 86 BYTES)

(Ex. 43 logical sector mode)

0001, 0002, 0003, 0004, 0005, 0006, 0007, 0008, 0009, 0013, 0015, 0016, 0017, 0018, 0019, 001A,.....0029, 002A, 002B

DON'T CARE (426 BYTES ATTACHED)

0000, 0000, 0000, 0000, 0000, 0000, 0000, 0000, 0000, 0000, 0000, 0000, 0000, 0000, 0000, 0000.

11.8.13 Seek (7xh)

COMMAND CODE	0 1 1 1 X X X X	REGISTER
REGISTER SETTING		NORMAL COMPLETION
DR	drive no.	no change
CY	cylinder to seek	no change
HD	head to seek	no change
SN		no change
SC		no change
FT		no change
LBA	address to seek	no change

This command moves the R/W heads to the cylinder specified in the task files. The drive sets BSY and starts seek operation. After the completion of a seek operation, the drive asserts DSC⁸, negates BSY, and return the interrupt.

If CY, HD and SN registers show invalid address, "ID Not Found" error is reported and no seek operation shall be executed. All commands related to data access possess Implied Seek function and don't need this command.

11.8.14 Toshiba Specific

COMMAND CODE	1 0 0 0 X X X X
	1 0 0 1 1 0 1 0
	1 1 1 1 0 0 0 0
	1 1 1 1 0 1 1 1
	1 1 1 1 1 0 1 X
	1 1 1 1 1 1 X X

These commands are only for factory use. Host must not issue them.

⁸ ATA-2 Notes: Prior to ATA-2 standard, this bit indicated that the device was on track. This bit may be used for other purposes in future standards. For compatibility the drive supports this bit as ATA-1 specifies. User is recommended not to use this bit.

11.8.15 Execute Diagnostics (90h)

COMMAND CODE		1 0 0 1 0 0 0 0	REGISTER
		REGISTER SETTING	NORMAL COMPLETION
DR			OOH
CY			OOH
HD			OOH
SN			O1H
SC			O1H
FT			

This command enables the drive to execute following self-test and reports the results to the error register described in Table 10.7.2-1.

- (1) ROM checksum test
- (2) RAM test
- (3) Controller LSI register test

An interrupt is generated at the completion of this command.

When two drives are daisy-chained on the interface, both drives execute the self test and the Drive0 reports valid error information of the two drives.

11.8.16 Initialize Device Parameters (91h)

COMMAND CODE		1 0 0 1 0 0 0 1	REGISTER
		REGISTER SETTING	NORMAL COMPLETION
DR	drive number		no change
CY			no change
HD	total number of heads-1		no change
SN	number of sector per track		no change
SC			no change
FT			no change

This command specifies the number of sectors per track and the number of heads per cylinder to set head switching point and cylinder increment point. Specified values affect Number of the current logical heads, Number of logical sectors per track, which can be read by Identify Device Command.

On issuing this command, the content of CY register shall not be checked. This command will be terminated with ABORT error when it is issued on a invalid HD or SC register setting (SC register=0 or the combination of HD and SC register exceeds the drive parameter.

Any drive access command should accompany correct HD, SN register with heads and sectors within the number specified for this command. Otherwise, it results in "ID not found" error. If the number of heads and drives is within the specified number, command gives parameter to convert an address to access into Logical Block Address (LBA). " ID Not Found " error also occur when this LBA exceeds the total number of user addressable sectors. The command does not affect LBA address mode.

11.8.17 Download Microcode (92h)

COMMAND CODE	1 0 0 0 0 0 1 0	REGISTER
REGISTER SETTING		NORMAL COMPLETION
DR	drive number	no change
CY		00h
HD		no change
SN	number of sector(high order)	00h
SC	number of sector(low order)	00h
FT	subcommand code	no change

This command enables the host to alter the device's microcode. The data transferred using the DOWNLOAD MICROCODE command is vendor specific.

All transfers shall be an integer multiple of the sector size. The size of the data transfer is determined by the contents of the Sector Number register and the Sector Count register. The Sector Number register shall be used to extend the Sector Count register to create a 16-bit sector count value. The Sector Number register shall be the most significant eight bits and the Sector Count register shall be the least significant eight bits. A value of zero in both the Sector Number register and the Sector Count register shall specify no data is to be transferred. This allows transfer sizes from 0 bytes to 33,553,920 bytes, in 512 byte increments.

The Features register shall be used to determine the effect of the DOWNLOAD MICROCODE command. The values for the Features register are:

- 07h - save downloaded code for immediate and future use.

This feature(07h) is supported. All other values are reserved.

11.8.18 Read Multiple (C4h)

COMMAND CODE	1 1 0 0 0 1 0 0	REGISTER
REGISTER SETTING		NORMAL COMPLETION
DR	drive number	no change
CY	starting cylinder	last possible
HD	starting head	last possible
SN	starting sector	last possible
SC	number of sector to read	00H
FT		no change
LBA	starting address	last possible

The read multiple command performs similarly to the Read Sectors command except for the following features. Interrupts are not issued on each sector, but on the transfer of each block which contains the number of sectors defined by a Set Multiple Mode command or the default, if no intervening Set Multiple command has been issued.

Command execution is identical to the Read Sectors operation except that the number of sectors defined by a Set Multiple Mode command are transferred without interrupts. DRQ qualification of the transfer is required only at the start of a data block transfer, not required for the transfer of each sector.

The block count of sectors to be transferred without intervening interrupts is programmed by the Set Multiple Mode command, which shall be executed prior to the Read Multiple command.

When the Read Multiple command is issued, the Sector Count Register contains the number of required sectors (not the number of blocks or the block count). If the number of required sectors is not evenly divisible by the block count, The redundant sectors are transferred during the final partial block transfer. The partial block transfer shall be for N sectors, where

$$N = \text{The redundant sector count (block count)}$$

If the Read Multiple command is attempted when Read Multiple command are disabled, the Read Multiple operation shall be rejected with an Aborted Command error.

Disk errors occurred during Read Multiple command are posted at the beginning of the block or partial block transfer, but DRQ is still set and the data, including corrupted data, shall be transferred as they normally would .

The contents of the Command Block Registers following the transfer of a data block which has a sector in error are undefined. The host should retry the transfer as individual requests to obtain valid error information.

Subsequent blocks or defective blocks are transferred only when the error is a correctable data error. All other errors after the transfer of the block containing the error terminates the command . Interrupts are generated when DRQ is set at the beginning of each block or partial block.

11.8.19 Read Multiple EXT (29h)

COMMAND CODE		0 0 1 0 1 0 0 1	REGISTER	
REGISTER SETTING			NORMAL COMPLETION	
DR		drive no.	no change	
LBA	Current	LBA(7:0)	HOB=0	last address
Low	Previous	LBA(31:24)	HOB=1	last address
LBA	Current	LBA(15:8)	HOB=0	last address
Mid	Previous	LBA(39:32)	HOB=1	last address
LBA	Current	LBA(23:16)	HOB=0	last address
High	Previous	LBA(47:40)	HOB=1	last address
SC	Current	sector count(7:0)	HOB=0	00H
	Previous	sector count(15:8)	HOB=1	00H
FT	Current	reserved	HOB=0	no change
	Previous	reserved	HOB=1	no change

This command is basically identical to Read Multiple command except register setting. This command is available in LBA addressing only.

11.8.20 Write Multiple (C5h)

COMMAND CODE		1 1 0 0 0 1 0 1	REGISTER	
REGISTER SETTING			NORMAL COMPLETION	
DR		drive number	no change	
CY		starting cylinder	last possible	
HD		starting head	last possible	
SN		starting sector	start sector	
SC		number of sector to write	00H	
FT			no change	
LBA		starting address	last possible	

This command performs similarly to the Write Sectors command except for the following features. The Drive sets BSY immediately upon receipt of the command, and interrupts are not issued on each sector but on the transfer of each block which contains the number of sectors defined by Set Multiple Mode command or the default if no intervening Set Multiple command has been issued.

Command execution is identical to the Write Sectors operation except that no interrupt is generated during the transfer of number of sectors defined by the Set Multiple Mode command but generated for each block. DRQ qualification of the transfer is required only for each data block, not for each sector.

The block count of sectors to be transferred without programming of intervening interrupts by the Set Multiple Mode command, which shall be executed prior to the Write Multiple command.

When the Write Multiple command is issued, the host sets the number of sectors (not the number of blocks or the block count) it requests in the Sector Count Register. If the number of required sectors is not evenly divisible by the block count, the redundant sectors are transferred during the final partial block transfer. The partial block transfer shall be for N sectors, where

$$N = \text{The redundant sector count (block count)}$$

If the Write Multiple command is attempted when Write Multiple command are disabled, the Write Multiple operation shall be rejected with an Aborted Command error.

Disk errors occurred during Write Multiple command are posted after the attempted disk write of the block or partial block which are transferred. The Write Multiple command is terminated at the sector in error , even if it was in the middle of a block. Subsequent blocks are not transferred after an error. Interrupts are generated for each block or each sector, when DRQ is set .

After the transfer of a data block which contains a sector with error, the contents of the Command Block Registers are undefined. The host should retry the transfer as individual requests to obtain valid error information.

11.8.21 Write Multiple EXT (39h)

COMMAND CODE		0 0 1 1 1 0 0 1	REGISTER	
		REGISTER SETTING	NORMAL COMPLETION	
DR		drive no.	no change	
LBA	Current	LBA(7:0)	HOB=0	last address
Low	Previous	LBA(31:24)	HOB=1	last address
LBA	Current	LBA(15:8)	HOB=0	last address
Mid	Previous	LBA(39:32)	HOB=1	last address
LBA	Current	LBA(23:16)	HOB=0	last address
High	Previous	LBA(47:40)	HOB=1	last address
SC	Current	sector count(7:0)	HOB=0	00H
	Previous	sector count(15:8)	HOB=1	00H
FT	Current	reserved	HOB=0	no change
	Previous	reserved	HOB=1	no change

This command is basically identical to Write Multiple command except register setting.

This command is available in LBA addressing only.

11.8.22 Set Multiple Mode (C6h)

COMMAND CODE		1 1 0 0 0 1 1 0	REGISTER	
		REGISTER SETTING	NORMAL COMPLETION	
DR		drive no.	no change	
CY			no change	
HD			no change	
SN			no change	
SC		The number of sectors / block	no change	
FT			no change	

This command enables the drive to perform Read and Write Multiple operations and sets the block count for these commands.

The Sector Count Register is loaded with the number of sectors per block. The drive supports 1,2,4,8 or 16 sectors per block.

Upon receipt of the command, the drive sets BSY=1 and checks the content of Sector Count Register.

If the Sector Count Register contains a valid value and the block count is supported, the value is loaded for all subsequent Read Multiple and Write Multiple commands. And these commands are enabled to be executed. If a block count is not supported, this command shall be terminated with the report of an Aborted Command error, and Read Multiple and Write Multiple commands are disabled.

If the Sector Count Register contains 0 when the command is issued, Read Multiple and Write Multiple commands are disabled.

In case of software reset, the result depends on the setting of Set Feature command. If FT=66h, the mode is not changed. If FT = CCh, the mode reverts to power on default (16 sectors).

11.8.23 Read DMA (C8h/C9h)

COMMAND CODE		1 1 0 0 1 0 0 X	REGISTER
		REGISTER SETTING	NORMAL COMPLETION
DR		drive no.	no change
CY		starting cylinder	last possible
HD		starting head	last possible
SN		starting sector	last possible
SC		no. of sector to read	00H
FT			no change
LBA		starting address	last address

This command is basically identical to Sector command except following features.

- Host initialize the DMA channel before issuing command.
 - Data transfer is initiated by DMARQ and handled by the DMA channel in the host.
 - Drive issues only one interrupt at the completion of each command to show the status is valid after data transfer.

During DMA transfer phase, either BSY or DRQ is set to 1.

When a command is completed, CY, HD, SN register (LBA register) shows the sector transferred the latest.

If the drive detects unrecoverable error, the drive terminate the command and CY, HD, SN register (LBA register) shows the sector where error occurred.

11.8.24 Read DMA EXT (25h)

COMMAND CODE		0 0 1 0 0 1 0 1	REGISTER
		REGISTER SETTING	NORMAL COMPLETION
DR		drive no.	no change
LBA	Current	LBA(7:0)	HOB=0 last address
Low	Previous	LBA(31:24)	HOB=1 last address
LBA	Current	LBA(15:8)	HOB=0 last address
Mid	Previous	LBA(39:32)	HOB=1 last address
LBA	Current	LBA(23:16)	HOB=0 last address
High	Previous	LBA(47:40)	HOB=1 last address
SC	Current	sector count(7:0)	HOB=0 00H
	Previous	sector count(15:8)	HOB=1 00H
FT	Current	reserved	HOB=0 no change
	Previous	reserved	HOB=1 no change

This command is basically identical to Read DMA command except register setting.

This command is available in LBA addressing only.

11.8.25 Write DMA (CAh/CBh)

COMMAND CODE		1 1 0 0 1 0 1 X	REGISTER
REGISTER SETTING			NORMAL COMPLETION
DR		drive no.	no change
CY		starting cylinder	last possible
HD		starting head	last possible
SN		starting sector	last possible
SC		no. of sector to write	00H
FT			no change
LBA		starting address	last address

This command is basically identical to Sector command except following differences.

- Host initialize the DMA channel before issuing command.
 - Data transfer is initiated by DMARQ and handled by the DMA channel in the host.
 - Drive issue only one interrupt at the completion of each command to show the status is valid after data transfer.

During DMA transfer phase, either BSY or DRQ is set to 1.

When a command is completed, CY, HD, SN register (LBA register) shows the sector transferred the latest.

If the drive detects unrecoverable error, the drive terminates the command and CY, HD, SN register (LBA register) shows the sector where error has occurred.

11.8.26 Write DMA EXT (35h)

COMMAND CODE		0 0 1 1 0 1 0 1	REGISTER
REGISTER SETTING			NORMAL COMPLETION
DR		drive no.	no change
LBA	Current	LBA(7:0)	HOB=0 last address
Low	Previous	LBA(31:24)	HOB=1 last address
LBA	Current	LBA(15:8)	HOB=0 last address
Mid	Previous	LBA(39:32)	HOB=1 last address
LBA	Current	LBA(23:16)	HOB=0 last address
High	Previous	LBA(47:40)	HOB=1 last address
SC	Current	sector count(7:0)	HOB=0 00H
	Previous	sector count(15:8)	HOB=1 00H
FT	Current	reserved	HOB=0 no change
	Previous	reserved	HOB=1 no change

This command is basically identical to Write DMA command except register setting.

This command is available in LBA addressing only.

11.8.27 Power Control (Exh)

COMMAND CODE	1 1 1 0 X X X X	REGISTER
REGISTER SETTING		NORMAL COMPLETION
DR	drive no.	no change
CY		no change
HD		no change
SN		no change
SC	shown below	00/FFH (for E5/98 command) no change (for other command)
FT		no change

Power Control is a group of commands which controls low power mode in the drive. The drive has three types of power mode:

Idle, Stand-by and Sleep mode

At the completion of disk access, the drive automatically enters the idle mode.

There are two ways to shift to the stand-by mode (to stop rotation of spindle motor).

- By a command from the host
- By internal timer

The internal timer is set by Stand-by or Idle command. If the drive receives disk access command from the host when it is in stand-by mode , the spindle starts rotating and the drive executes read/write operation.

After power on, the spindle starts rotating and enters the idle mode. During idle or stand-by, READY bit is set and the drive is ready to receive a command.

To be specific , there are four different sub-commands defined by lower 4 bits of command as follows. The drive is in the idle mode when it is in default condition after power- on.

11.8.27.1 Stand-by Immediate (E0/94)

SC=X (Don't care)

The drive enters the stand-by mode immediately by this command. If the drive is already in the stand-by mode, it does no-operation and the stand-by timer doesn't start .The drive issues an interrupt and reports the host that the command has been completed before it virtually enters the stand-by mode .

11.8.27.2 Idle Immediate (E1/95)

SC=X

The drive enters the idle mode immediately by this command. If the drive is already in the idle mode, it does no-operation. If stand-by timer is enabled, timer will start. After the drive enters the idle mode, the drive issues interrupt to report the host that the command has been completed.

11.8.27.3 Stand-by (E2/96)

This command causes the device to enter stand-by mode.

If SC is non-zero then stand-by timer shall be enabled. The value in SC shall be used to determine the time programmed into the stand-by timer.

If SC is zero then the stand-by timer is disabled.

Value in SC register	Setting
0	Time out disabled
1-240	(SC x 5) sec.
241-251	((value - 240) x 30) min.
252	21 min
253	Period between 8 and 12 hrs
254	Reserved
255	21 min 15 sec.

When the specified time period has passed, the drive enters stand-by mode. If a disk access command is received during stand-by mode, the spindle starts rotating and the drive executes read/write operation. After completing the command, the drive reset stand-by timer and the timer starts counting down.

11.8.27.4 Idle (E3/97)

This command causes the device to enter idle mode.

If SC is non-zero then stand-by timer shall be enabled. The value in SC shall be used to determine the time programmed into the stand-by timer.

If SC is zero then the stand-by timer is disabled.

Value in SC register	Setting
0	Time out disabled
1-240	(SC x 5) sec.
241-251	((value - 240) x 30) min.
252	21 min
253	Period between 8 and 12 hrs
254	Reserved
255	21 min 15 sec.

When the specified time period has expired, the drive enters the stand-by mode. If disk access command is received during the stand-by mode, the spindle starts rotating and executes read/write operation. After completing the command, The drive resets stand-by timer and the timer starts counting down.

11.8.27.5 Check Power Mode (E5/98)

SC result value=00 indicates that the drive is in stand-by mode or going into stand-by mode or is shifting from stand-by mode into idle mode.

SC result value=FFH indicates that the drive is in idle mode.

11.8.27.6 Sleep (E6/99)

When SC=X, the drive enters sleep mode immediately. After entering the sleep mode, the drive issues an interrupt to report the host that the command has been completed. The drive recovers from sleep mode and enters stand-by mode by receiving a reset.

11.8.28 Read Buffer (E4h)

COMMAND CODE		1 1 1 0 0 1 0 0	REGISTER
REGISTER SETTING		NORMAL COMPLETION	
DR	drive no.	no change	
CY		no change	
HD		no change	
SN		no change	
SC		00H	
FT		no change	

This command transfers a specified sector of data (512 bytes) from the 128kB buffer in the drive to the host. When this command is issued, the drive sets BSY, sets up the buffer for read operation, sets DRQ, resets BSY, and generates an interrupt. The host reads up to 512 bytes of data from the buffer.

11.8.29 Write Buffer (E8h)

COMMAND CODE		1 1 1 0 1 0 0 0	REGISTER
REGISTER SETTING		NORMAL COMPLETION	
DR	drive no.	no change	
CY		no change	
HD		no change	
SN		no change	
SC		00H	
FT		no change	

This command transfers a sector of data from the host to the specified 512 bytes of 128kB buffer of the drive . When this command is issued, the drive will set up the buffer for write operation, and set DRQ. The host may then write up to 512 bytes of data to the buffer.

11.8.30 Identify Device (ECh)

COMMAND CODE		1 1 1 0 1 1 0 0	REGISTER
REGISTER SETTING		NORMAL COMPLETION	
DR	drive no.	no change	
CY		no change	
HD		no change	
SN		no change	
SC		00H	
FT		no change	

The identify device command requests the drive to transfer parameter information to the host. When the command is issued, the drive sets BSY, stores the required parameter information in the sector buffer, sets the DRQ bit, and issues an interrupt. The host may read the parameter information of the sector buffer. The parameter words in the buffer are arranged as shown in Table 11.8-1 ~ Table 11.8-5.

Table 11.8-1 Identify Information

WORD	DESCRIPTION	Hex.
0	General configuration 15 0=ATA device 14-8 Reserved 7 1=Removable cartridge device 6 1=Fixed device 5-3 Reserved 2 Response incomplete 1-0 Reserved	0040
1	Number of default logical cylinders	[1*]
2	Specific configuration	C837
3	Number of default logical heads	[2*]
4	Reserved	0000
5	Reserved	0000
6	Number of default logical sectors h logical track	[3*]
7-9	Reserved	
10-19	Serial Number (20 ASCII characters)	
20	Reserved	0000
21	Reserved	0000
22	Reserved	0000
23-26	Firmware Revision (8 ASCII characters)	
27-46	Controller model # (40 ASCII characters)	
47	15-8 80h 7-0 00 _H = READ/WRITE MULTIPLE command not implemented 01 _H - FF _H = Maximum number of sectors that can be transferred per interrupt on READ/WRITE MULTIPLE commands	8010
48	Reserved	0000
49	Capabilities 15-14 Reserved 13 1=Standby timer values as specified in ATA/ATAPI-6 specification are supported 0=Standby timer values are vendor specific 12 Reserved 11 1=ORDY supported 10 1=ORDY can be disabled 9 1=LBA supported 8 1=DMA supported 7-0 Reserved	2F00
50	Capabilities 15 0 (Fixed) 14 1 (Fixed) 13-1 Reserved 0 1= a device specific Standby timer value minimum.	4000
51	15-8 PIO data transfer cycle timing mode 7-0 Reserved	0200
52	Reserved	0000
53	15-3 Reserved 2 1=the fields reported word 88 are valid 0=the fields reported word 88 are not valid 1 1=the fields reported words 64-70 are valid 0=the fields reported words 64-70 are not valid 0 1=the fields reported words 54-58 are valid 0=the fields reported words 54-58 are not valid	0007
54	Number of current cylinders	XXXX
55	Number of current heads	XXXX
56	Number of current sectors per track	XXXX

Table 11.8-2 Identify Information (Continued)

WORD	DESCRIPTION	Hex.
57-58	Current capacity in sectors (Number of current cylinders * Number of current heads * Number of current sectors per track)	XXXX
59	15-9 Reserved 8 1=Multiple sector setting is valid 7-0 XXh=Current setting for number of sectors that can be transferred per interrupt on R/W Multiple command	01XX
60-61	Total number of user addressable sectors (LBA mode only)	[5*]
62	15-0 Reserved	XX07
63	15-8 Multiword DMA transfer mode active 7-0 Multiword DMA transfer mode supported	XX07
64	15-8 reserved 7-0 Advanced PIO Transfer Modes Supported bit 7-2 Reserved bit 1 = 1 PIO MODE 4 supported bit 0 = 1 PIO MODE 3 supported	0003
65	Minimum Multiword DMA Transfer Cycle Time Per Word (ns)	0078
66	Manufacturer's Recommended Multiword DMA Transfer Cycle Time	0078
67	Minimum PIO Transfer Cycle Time Without Flow Control (ns)	0078
68	Minimum PIO Transfer Cycle Time With IOCHRDY Flow Control	0078
69-79	Reserved (for future command overlap and queuing)	0000
80	Major version number 0000h or FFFFh = device does not report version 15-7 Reserved for ATA-7-14 6 1=supports ATA/ATAPI-6 5 1=supports ATA/ATAPI-5 4 1=supports ATA/ATAPI-4 3 1=supports ATA-3 2 1=supports ATA-2 1 1=supports ATA-1 0 Reserved	007E
81	Minor version number 0000h or FFFFh = device does not report version	0000
82	Command set supported. 0000h or FFFFh = command set notification not supported 15 Reserved 14 1=NOP command supported 13 1=READ BUFFER command supported 12 1=WRITE BUFFER command supported 11 Reserved 10 1=Host Protected Area feature set supported 9 1=DEVICE RESET command supported 8 1=SERVICE interrupt supported 7 1=release interrupt supported 6 1=look-ahead supported 5 1=write cache supported 4 1=supports PACKET Command feature set 3 1=supports power management feature set 2 1=supports removable feature set 1 1=supports security feature set 0 1=supports SMART feature set	746B

Table 11.8-3 Identify Information (Continued)

WORD	DESCRIPTION	Hex.
83	Command set supported. 0000h or FFFFh = command set notification not supported 15 0 (Fixed) 14 1(Fixed) 13 1=FLUSH CACHE EXT command supported 12 1=FLUSH CACHE command supported 11 1=Device Configuration Overlay supported 10 1=48-bit Address feature set supported 9 1=Automatic Acoustic Management feature set supported 8 1=Set MAX security extension supported 7 Reserved 6 1=SET FEATURES subcommand required to spin up after power-up 5 1=Power-Up in Standby feature set supported 4 1=Removable Media Status Notification feature set supported 3 1=Advanced Power Management feature set supported 2 1=CFA feature set supported 1 1=READ / WRITE DMA QUEUED supported 0 1=DOWNLOAD MICROCODE command supported	7D09
84	Command set/feature supported extension 15 0 (Fixed) 14 1(Fixed) 13 1(Fixed) 12-6 Reserved 5 1=General Purpose Logging feature set supported 4 1=Reserved 3 1=Media Card Pass Through Command feature set supported 2 1=Media serial number supported 1 1=SMART self-test supported 0 1=SMART error logging supported	6023
85	Command set/feature enabled 15 Reserved 14 1=NOP command enabled 13 1=READ BUFFER command enabled 12 1=WRITE BUFFER command enabled 11 Reserved 10 1=Host Protected Area feature set enabled 9 1=DEVICE RESET command enabled 8 1=SERVICE interrupt enabled 7 1=release interrupt enabled 6 1=look -ahead enabled 5 1=write cache enabled 4 1=PACKET Command feature set supported 3 1=power management feature set enabled 2 1=removable feature set enabled 1 1=Security feature set enabled 0 1=SMART feature enabled	XXXX
86	Command set/feature enabled 15-14 Reserved 13 1=FLUSH CACHE EXT command supported 12 1=FLUSH CACHE command supported 11 1=Device Configuration Overlay supported 10 1=48-bit Address feature set supported 9 1=Automatic Acoustic Management feature set enabled 8 1=SET MAX security extension enabled by SET MAX SET PASSWORD 7 Reserved 6 1=SET FEATURES subcommand required to spin-up after power-up 5 1=Power-Up In Standby feature set enabled 4 1=Removable Media Status Notification feature set enabled 3 1=Advanced Power Management feature set enabled 2 1=CFA feature set enabled 1 1=READ / WRITE DMA QUEUED supported 0 1=DOWNLOAD MICROCODE command supported	XX0X

Table 11.8-4 Identify Information (Continued)

WORD	DESCRIPTION	Hex.
87	Command set/feature default 15 0 (Fixed) 14 1 (Fixed) 13 1 (Fixed) 12-6 Reserved 5 1=General Purpose Logging feature set supported 4 Reserved 3 1=Media Card Pass Through Command feature set enabled 2 1=Media serial number is valid 1 1=SMART self-test supported	6023
88	15-8 Ultra DMA transfer mode selected 7-0 Ultra DMA transfer modes supported	XX3F
89	Time required for security erase unit completion	00XX
90	Time required for Enhanced Security erase completion	0000
91	Current Advanced Power Management setting 15-8 Reserved 7-0 Current Advanced Power Management setting set by Set Features Command	00XX
92	Master Password Revision Code	XXXX
93	Hardware reset result. The contents of bits 12-0 of this word shall change only during the execution of a hardware reset. 15 0 (Fixed) 14 1 (Fixed) 13 1=device detected CBLID- above V_{IH} 0=device detected CBLID- below V_{IL} 12-8 Device 1 hardware reset result. Device 0 shall clear these bits to zero. Device 1 shall set these bits as follows : 12 Reserved. 11 0=Device 1 did not assert PDIAG-. 1=Device 1 asserted PDIAG-. 10-9 These bits indicate how Device 1 determined the device number: 00=Reserved. 01=a jumper was used. 10=the CSEL signal was used. 11=some other method was used or the method is unknown. 8 1 (Fixed) 7-0 Device 0 hardware reset result. Device 1 shall clear these bit to zero. Device 0 shall set these bills as follows: 7 Reserved. 6 0=Device 0 does not respond when Device 1 is selected. 1=Device 0 responds when Device 1 is selected. 5 0=Device 0 did not detect the assertion of DASP-. 1=Device 0 detected the assertion of DASP-. 4 0=Device 0 did not detect the assertion of PDIAG-. 1=Device 0 detected the assertion of PDIAG-. 3 0=Device 0 failed diagnostics. 1=Device 0 passed diagnostics. 2-1 These bits indicate how Device 0 determined the device number: 00=Reserved. 01=a jumper was used. 10=the CSEL signa was used. 11=some other method was used or the method is unknown. 0 1 (Fixed)	XXXX
94	Current automatic acoustic management value 15-8 Vendor's recommended acoustic management value 7-0 Current automatic acoustic management value	0000
95-99	Reserved	0000
100-103	Maximum user LBA for 48-bit Address feature set	XXXX
104-126	Reserved	0000

Table 11.8-5 Identify Information (Continued)

WORD	DESCRIPTION	Hex.
127	Removable Media Status Notification feature set supported 15-2 Reserved 1-0 00=Removable Media Status Notification feature set not supported 01=Removable Media Status Notification feature set supported 10=Reserved 11=Reserved	0000
128	Security status 15-9 Reserved 8 Security level 0=High, 1=Maximum 7-6 Reserved 5 1=Enhanced security erase supported 4 1=Security count expired 3 1=Security frozen 2 1=Security locked 1 1=Security enabled 0 1=Security supported	0XXX
129-159	Reserved	0000
160	CFA power mode 1 15 Word 160 supported 14 Reserved 13 CFA power mode 1 is required for one or more commands implemented by the device 12 CFA power mode 1 disabled 11-0 Maximum current in ma	0000
161-175	Reserved	0000
176-205	Current media serial number	0000
206-254	Reserved	0000
255	Integrity word 15-8 Checksum 7-0 Signature	XXA5

Word descriptions:

WORD 0: General configuration

bit 15 0=ATA
bit 14-8 Reserved
bit 7 1=Removable cartridge
bit 6 1=Fixed disk drive
bit 5-3 Reserved
bit 2 Response incomplete
bit 1-0 Reserved

The value for this WORD is 0040h.

WORD 1: Logical cylinder number that user can access (in default mode) [*1]

WORD 2: Specific configuration

“37C8” : Device requires SET FEATURES subcommand to spin-up after power-up and IDENTIFY DEVICE response is incomplete.
“738C” : Device requires SET FEATURES subcommand to spin-up after power-up and IDENTIFY DEVICE response is complete.
“8C73” : Device does not requires SET FEATURES subcommand to spin-up after power-up and IDENTIFY DEVICE response is incomplete.
“C837” : Device does not requires SET FEATURES subcommand to spin-up after power-up and IDENTIFY DEVICE response is complete.
“All other valies” : Reserved

Power-up in Standby feature set is not supported.

The value for this WORD is C837h.

WORD 3: Logical head number that user can access (in default mode) [*2]

WORD 4-5: Reserved

WORD 6: The number of logical sector per track (in default mode) [*3]

Default Values : [*1],[*2],[*3]

Drive Type	[*1] : Word 1	[*2] : Word 3	[*3] : Word 6
MK3006GAL	16383	16	63
MK4006GAH	16383	16	63
MK6006GAH	16383	16	63

WORD 7-9: Reserved

WORD 10-19: Serial number

WORD 20-21: Reserved

WORD 22: Reserved

WORD 23-26: Firmware revision (8 ASCII characters)

WORD 27-46: Model name (40 ASCII characters)

Drive Type	
MK3006GAL	TOSHIBA MK3006GAL _ _ _ _
MK4006GAH	TOSHIBA MK4006GAH _ _ _ _
MK6006GAH	TOSHIBA MK6006GAH _ _ _ _

“_” indicates ASCII space code.

WORD 47:

- bit 15 - 8 shall be set to 80h
- bit 7 - 0 Maximum number of sectors that can be transferred per interrupt on READ/WRITE MULTIPLE commands.

The default value for this WORD is 8010h.

WORD 48: Reserved

WORD 49: Capabilities

- bit 15-14 0=Reserved
- bit 13 1=Standby timer value shall be as specified in ATA-/ ATAPI-6 specification
0=Standby timer value are vendor specific
- bit 12 Reserved (For advanced PIO mode support)
- bit 11 1=IORDY is supported.
- bit 10 1=IORDY function can be disabled.
- bit 9 1=LBA supported
- bit 8 1=DMA supported
- bit 7- 0 Reserved

The value for this WORD is 2F00h.

WORD 50: Capabilities

- bit 15 0 (Fixed)
- bit 14 1 (Fixed)
- bit 13-1 Reserved
- bit 0 1=device has a minimum Standby timer value that is device specific.

Standby timer value is set to 5 minutes or more. The value for this WORD is 4000h.

WORD 51: PIO data transfer cycle timing mode

- bit 15- 8 PIO data transfer cycle timing mode
- bit 7- 0 Reserved

The value returned in Bits 15-8 should fall into one of the mode 0 through mode.

Note: For backwards compatibility with BIOS written before Word 64 was defined for advanced modes, a device reports in Word 51 the highest original PIO mode (i.e. PIO mode 0, 1, or 2) it can support.

The value for this WORD is 0200h.

WORD 52: Reserved

WORD 53:

- bit15- 3 Reserved
- bit 2 1= the fields reported in word 88 is valid
- bit 1 1= the fields reported in words 64 ~ 70 are valid
- bit 0 1= the fields reported in words 54 ~ 58 are valid

If the number of heads and sectors exceed the drive parameter, bit 0 and related WORD 54-58 shall be cleared to 0. The default value for this WORD is 0007h.

WORD 54: Number of current cylinders defined by INITIALIZE DEVICE PARAMETERS command

WORD 55: Number of current heads defined by INITIALIZE DEVICE PARAMETERS command

WORD 56: Number of current sectors/track defined by INITIALIZE DEVICE PARAMETERS command

WORD 57-58: Total number of sectors calculated by word 54 - 56

- bit31-24 by word 58 bit 7- 0
- bit23-16 by word 58 bit 15- 8
- bit15- 8 by word 57 bit 7- 0
- bit 7- 0 by word 57 bit 15- 8

The power on values for each models are.

Drive Type	[*4] : Word 57 – 58
MK3006GAL	16,514,064(FBFC10H)
MK4006GAH	16,514,064(FBFC10H)
MK6006GAH	16,514,064(FBFC10H)

WORD 59:

- bit15- 9 Reserved
- bit 8 1=bit 7- 0 shows number of sectors for multiple sector operation (multiple sector operation is enabled by SET MULTIPLE command).
- bit 7 ~ 0 The number of sectors transferred for XX_H=Write / Read multiple command with 1 Interrupt (Current value shall be set by SET MULTIPLE command. The default value is 16).

The default value for this WORD is 0110h.

WORD 60-61: Maximum number of sectors that user can access in LBA mode

- bit31-24 by word 61 bit 7- 0
- bit23-16 by word 61 bit 15- 8
- bit15- 8 by word 60 bit 7- 0
- bit 7- 0 by word 60 bit 15- 8

The maximum value that shall be placed in this field is 0FFFFFFFh.

The power on values for each models are.

Drive Type	[*5] : Word 60 – 61
MK3006GAL	58,605,120(037E3E40H)
MK4006GAH	78,126,048 (04A81BE0H)
MK6006GAH	117,210,240 (06FC7C80H)

WORD 62: Reserved

WORD 63: Mode information for multiword DMA

- bit15- 8 Active mode
- bit 10 1=Mode 2 is active
- bit 9 1=Mode 1 is active
- bit 8 1=Mode 0 is active
- bit 7- 0 Supported mode
- bit 2 1=mode 2 is supported
- bit 1 1=mode 1 is supported
- bit 0 1=mode 0 is supported

Support bit reflects setting by SET FEATURE command.

The default value for this WORD is 0407h and the default figure is mode 2

WORD 64: Mode information for Advanced PIO transfer

- bit 7- 0 Supported mode
- bit 1 1=mode 4 is supported
- bit 0 1=mode 3 is supported

The value for this WORD is 0003h.

WORD 65: Minimum multiword DMA transfer mode cycle time per word (ns)

If this bit is supported, word 53 bit 1 shall be set. The value for this WORD is 0078h (120ns).

WORD 66: Manufacturer recommended multiword DMA transfer cycle time

If the data transfer is requested in a shorter cycle time than this definition, the data transfer may be kept pending with DMARQ low because data is not ready. The value for this WORD is 0078h (120ns).

WORD 67: Minimum PIO transfer cycle time without flow control (ns)

The Drive can guarantee correct data transfer without flow control in this cycle time or longer. If this bit is supported, word 53 bit 1 is to be set. The drives which support PIO mode 3 or higher shall support this field too. This figure shall not be less than 120. The value for this WORD is 0078h (120ns).

WORD 68: Minimum PIO transfer cycle time with IORDY flow control (ns)

If this bit is supported, word 53 bit 1 is to be set. The drive that support PIO mode 3 or higher shall support this field too. This figure shall not be less than 120. The value for this WORD is 0078h (120ns).

WORD 69-79: Reserved

WORD 80: Major version number

If not 0000h or FFFFh, the device claims compliance with the major version(s) as indicated by bits 1 - 6 being equal to one. Values other than 0000h and FFFFh are bit significant. Since the ATA standards maintain downward compatibility, a device may set more than one bit .

WORD 81: Minor version number

If an implementor claims that the revision of the standard they used to guide their implementation does not need to be reported or if the implementation was based upon a standard prior to this revision of the standard, Word 81 shall be 0000h or FFFFh.

WORD 82: Command sets supported

bit 15	Reserved
bit 14	NOP command supported
bit 13	READ BUFFER command supported
bit 12	WRITE BUFFER command supported
bit 11	Reserved
bit 10	Host Protected Area feature set supported
bit 9	DEVICE RESET command supported
bit 8	SERVICE interrupt supported
bit 7	Release Interrupt supported
bit 6	Look Ahead supported
bit 5	Write Cache supported
bit 4	PACKET feature set supported
bit 3	The Power Management feature set is supported
bit 2	The Removable feature set is supported
bit 1	The security feature set is supported
bit 0	The SMART feature set is supported

The value for this WORD is 746Bh.

WORD 83: Features/Command sets supported

bit 15	0 (Fixed)
bit 14	1 (Fixed)
bit 13	1=FLUSH CACHE EXT command supported
bit 12	1=FLUSH CACHE command supported
bit 11	1=Device Configuration Overlay supported
bit 10	1=48-bit Address feature set supported
bit 9	1=Automatic Acoustic Management feature set supported
bit 8	1=Set MAX security extension supported
bit 7	Reserved
bit 6	1=SET FEATURES subcommand required to spin up after power-up
bit 5	1=Power-Up in Standby feature set supported
bit 4	1=Removable Media Status Notification feature set supported
bit 3	Advanced Power Management feature set supported
bit 2	1=CFA feature set supported
bit 1	1=READ / WRITE DMA QUEUED supported
bit 0	1=DOWNLOAD MICROCODE command supported

The value for this WORD is 7D09h.

WORD 84: Features / Command sets supported

bit 15	0 (Fixed)
bit 14	1 (Fixed)
bit 13	1 (Fixed)
bit 12-6	Reserved
bit 5	1=General Purpose Logging feature set supported
bit 4	Reserved
bit 3	1=Media Card Pass Through command feature set supported
bit 2	1=Media serial number supported
bit 1	1=SMART self-test supported
bit 0	1=SMART error logging supported

The value for this WORD is 6023h.

WORD 85: Features / Command sets enable

bit 15	Reserved
bit 14	NOP command enabled
bit 13	READ BUFFER command enabled
bit 12	WRITE BUFFER command enabled
bit 11	Reserved
bit 10	Host Protected Area feature set enabled
bit 9	DEVICE RESET command enabled
bit 8	SERVICE interrupt enabled
bit 7	Release Interrupt enabled
bit 6	Look Ahead enabled
bit 5	Write Cache enabled
bit 4	PACKET feature set supported
bit 3	The Power Management feature set is enabled
bit 2	The Removable feature set is enabled
bit 1	The security feature set is enabled
bit 0	The SMART feature set is enabled

The default value for this WORD is 7468h

WORD 86: Features / Command sets enabled

- bit 15-14 Reserved
- bit 13 1=FLUCH CACHE EXT command supported
- bit 12 1=FLUSH CACHE command supported
- bit 11 1=Device Configuration Overlay supported
- bit10 1=48-bit Address feature set supported
- bit 9 1=Automatic Acoustic Management feature set enabled
- bit 8 1=SET MAX security extension enabled by SET MAX SET PASSWORD
- bit 7 Reserved
- bit 6 1=SET FEATURES subcommand required to spin-up after power-up
- bit 5 1=Power-Up In Standby feature set enabled
- bit 4 Removable Media Status Notification feature set enabled
- bit 3 Advanced power Management feature set enabled
- bit 2 CFA feature set enabled
- bit 1 WRITE / READ DMA QUEUED command supported
- bit 0 DOWNLOAD MICROCODE supported

The default value for this WORD is 3C09h.

WORD 87: Features / Command sets enabled

- bit 15 0 (Fixed)
- bit 14 1 (Fixed)
- bit 13 1 (Fixed)
- bit 12-6 Reserved
- bit 5 1=General Purpose Logging feature set supported
- bit 4 Reserved
- bit 3 1=Media Card Pass Through command feature set enabled
- bit 2 1=Media serial number is valid
- bit 1 1=SMART self-test supported
- bit 0 1=SMART error logging supported

The value for this WORD is 6023h.

WORD 88: Mode information for Ultra DMA

The active mode reflects the command change.

- bit 15-8 Active transfer mode
- bit 13 1=Mode 5 is active
- bit 12 1=Mode 4 is active
- bit 11 1=Mode 3 is active
- bit 10 1=Mode 2 is active
- bit 9 1=Mode 1 is active
- bit 8 1=Mode 0 is active
- bit 7-0 Supported mode
- bit 5 1=Mode 5 is supported
- bit 4 1=Mode 4 is supported
- bit 3 1=Mode 3 is supported
- bit 2 1=Mode 2 is supported
- bit 1 1=Mode 1 is supported
- bit 0 1=Mode 0 is supported

The default value for this WORD is 003Fh

WORD 89: The time period for Security Erase Unit command completion shall be set.

TIMER	ACTUAL VALUE
0	Not specified
1-254	(Timer x 2) minuites
255	> 508 minuites

WORD 90: Time required for Enhanced Security erase completion

WORD 91: Current Advanced Power Management setting

bit 15-8 Reserved

bit 7-0 Current Advanced Power Management setting set by Set Features Command.

The default value for this WORD is 0080h.

WORD 92: Master Password Revision Code

the value of the Master Password Revision Code set when the Master Password was last change. Valid values are 0001h through FFFEh. A value of 0000h or FFFFh indicates that the Master Password Revision is not supported.

WORD 93: Hardware configuration test results

bit 15 0 (Fixed)

bit 14 1 (Fixed)

bit 13 1=device detected CBLID- above V_{IH}

0=device detected CBLID- below V_{IL}

bit12-8 Device 1 hardware reset result. Device 0 shall clear these bits to zero.

Device 1 shall set these bits as follows :

12 Reserved.

11 0=Device 1 did not assert PDIAG-.

1=Device 1 asserted PDIAG-.

10-9 These bits indicate how Device 1 determined the device number:

00=Reserved.

01=a jumper was used.

10=the CSEL signal was used.

11=some other method was used or the method is unknown.

8 1 (Fixed)

bit 7-0 Device 0 hardware reset result. Device 1 shall clear these bit to zero.

Device 0 shall set these bills as follows:

7 Reserved.

6 0=Device 0 does not respond when Device 1 is selected.

1=Device 0 responds when Device 1 is selected.

5 0=Device 0 did not detect the assertion of DASP-.

1=Device 0 detected the assertion of DASP-.

4 0=Device 0 did not detect the assertion of PDIAG-.

1=Device 0 detected the assertion of PDIAG-.

3 0=Device 0 failed diagnostics.

1=Device 0 passed diagnostics.

2-1 These bits indicate how Device 0 determined the device number:

00=Reserved.

01=a jumper was used.

10=the CSEL signa was used.

11=some other method was used or the method is unknown.

0 1 (Fixed)

WORD 94: Current automatic acoustic management value

bit 15-8 Vendor's recommended acoustic management value

bit 7-0 Current automatic acoustic management value

This function is not supported. The value for this WORD is 0000h.

WORD 95-99: Reserved

WORD 100-103: Maximum User LBA for 48-bit Address feature set

The value for this WORD is XXXXh.

WORD 104-126: Reserved

WORD 127: Removable Media Status Notification feature set supported

This function is not supported. The value for this WORD is 0000h.

WORD 128: Security status

bit 15-9 Reserved

bit 8 the security level.

1=the security level is maximum

0=the security level is high

bit 5 1=the Enhanced security erase unit feature supported

bit 4 the security count has expired.

1=the security count is expired and SECURITY UNLOCK and SECURITY ERASE UNIT are aborted until receiving a power-on reset or hard reset.

bit 3 security frozen.

1=the drive is in security frozen mode.

bit 2 security locked.

1=the drive is in security locked mode.

bit 1 security enabled.

1=the security is enabled.

bit 0 security supported.

1=security is supported.

WORD 129-159: Reserved

WORD 160: CFA power mode

bit 15 Word 160 supported

bit 14 Reserved

bit 13 CFA power mode 1 is required for one or more commands implemented by the device

bit 12 CFA power mode 1 disabled

bit 11-0 Maximum current in ma

This function is not supported. The value for this WORD is 0000h.

WORD 161-175: Reserved

WORD 176-205: Current media serial number

This function is not supported. The value for this WORD is 0000h.

WORD 206-254: Reserved

WORD 255: Integrity word

The data structure checksum is the two's complement of the sum of all bytes in words 0 through 254 and the byte consisting of bits 7:0 in word 255. Each byte shall be added with unsigned arithmetic, and overflow shall be ignored. The sum of all 512 bytes is zero when the checksum is correct.

11.8.31 SET MAX (F9h)

Individual SET MAX commands are identified by the value placed in the Features register. Table 11.8-6 shows these Features register values. But regardless of Feature register value, the case this command is immediately preceded by a Read Native Max ADDRESS command, it is interpreted as a Set Max ADDRESS command.

Table 11.8-6 SET MAX Features register values

Value	Command
00h	Obsolete
01h	SET MAX SET PASSWORD
02h	SET MAX LOCK
03h	SET MAX UNLOCK
04h	SET MAX FREEZE LOCK
05h-FFh	Reserved

11.8.31.1 Set Max Address

COMMAND CODE	1 1 1 1 1 0 0 1	REGISTER
REGISTER SETTING		NORMAL COMPLETION
DR	DRIVE No.	no change
CY	Max. cylinder number	no change
HD	Max. head number	no change
SN	Max. sector number	no change
SC	00 _H / 01 _H (BIT0: reserved bit)	no change
FT		no change
LBA	Max. LBA	no change

This command specifies the the maximum address in a range of actual drive capacity. The values set in CY, HD, SN registers indicate the maximum address that can be accessed. In CHS mode, the value of Read Native Max Address command should be set in HD, SN register. Otherwise, the value shall be ignored and the value of Read Max Address command will be used. If an LBA bit (DRV / HD register bit 6) is set, the value in LBA mode shall be set. If the address exceeding the set value is accessed , " ABORT ERROR " error will be reported. This set value affects the values of WORD 1, 54, 57, 58, 60, 61, 100-103 of IDENTIFY DEVICE command.

This command shall be immediately preceded by Read Native Max Address command. Otherwise, it will be terminated with " ABORT ERROR " .

If this command is issued twice with a volatile bit set to 1 after power-up or hardware reset, "ID Not Found error" will be reported.

If a host protected area has been established by a SET MAX ADDRESS EXT command, this command will be terminated with " ABORT ERROR " .

Volatile bit (SC register bit 0) :

If this command is issued with a volatile bit set to 1, the set value of this command is valid after power-up or hardware reset.

If this command is issued with a volatile bit cleared to 0, the set value of this command shall be cleared after hard reset or power-on and the maximam value shall be the last value with a volatile bit set to 1.

11.8.31.2 Set Max Set Password

F9h with the content of the Features register equal to 01h.

COMMAND CODE		1 1 1 1 1 0 0 1	REGISTER
REGISTER SETTING			NORMAL COMPLETION
DR	DRIVE No.	01 _H	no change
CY			no change
HD			no change
SN			no change
SC			no change
FT			no change
LBA			no change

This command is not immediately preceded by a READ NATIVE MAX ADDRESS command. If this command is immediately preceded by a READ NATIVE MAX ADDRESS command, it shall be interpreted as a SET MAX ADDRESS command.

This command requests a transfer of a single sector of data from the host. Table 11.8-7 defines the content of this sector of information. The password is retained by the device until the next power cycle. When the device accepts this command the device is in Set_Max_Unlocked state.

Table 11.8-7 SET MAX SET PASSWORD data content

Word	Content
0	Reserved
1-16	Password (32 bytes)
17-255	Reserved

11.8.31.3 Set Max Lock

F9h with the content of the Features register equal to 02h.

COMMAND CODE		1 1 1 1 1 0 0 1	REGISTER
REGISTER SETTING			NORMAL COMPLETION
DR	DRIVE No.	02 _H	no change
CY			no change
HD			no change
SN			no change
SC			no change
FT			no change
LBA			no change

This command is not immediately preceded by a READ NATIVE MAX ADDRESS command. If this command is immediately preceded by a READ NATIVE MAX ADDRESS command, it shall be interpreted as a SET MAX ADDRESS command.

The SET MAX LOCK command sets the device into Set_Max_Locked state. After this command is completed any other SET MAX commands except SET MAX UNLOCK and SET MAX FREEZE LOCK are rejected. The device remains in this state until a power cycle or the acceptance of a SET MAX UNLOCK or SET MAX FREEZE LOCK command.

11.8.31.4 Set Max Unlock

F9h with the content of the Features register equal to 03h.

COMMAND CODE		1 1 1 1 1 0 0 1	REGISTER
REGISTER SETTING		NORMAL COMPLETION	
DR	DRIVE No.	03 _H	no change
CY			no change
HD			no change
SN			no change
SC			no change
FT			no change
LBA			no change

This command is not immediately preceded by a READ NATIVE MAX ADDRESS command. If this command is immediately preceded by a READ NATIVE MAX ADDRESS command, it shall be interpreted as a SET MAX ADDRESS command.

This command requests a transfer of a single sector of data from the host. Table 11.8-7 defines the content of this sector of information.

The password supplied in the sector of data transferred shall be compared with the stored SET MAX password.

If the password compare fails, then the device returns command aborted and decrements the unlock counter. On the acceptance of the SET MAX LOCK command, this counter is set to a value of five and shall be decremented for each password mismatch when SET MAX UNLOCK is issued and the device is locked. When this counter reaches zero, then the SET MAX UNLOCK command shall return command aborted until a power cycle.

If the password compare matches, then the device shall make a transition to the Set_Max_Unlocked state and all SET MAX commands shall be accepted.

11.8.31.5 Set Max Freeze Lock

F9h with the content of the Features register equal to 04h

COMMAND CODE		1 1 1 1 1 0 0 1	REGISTER
REGISTER SETTING		NORMAL COMPLETION	
DR	DRIVE No.	04 _H	no change
CY			no change
HD			no change
SN			no change
SC			no change
FT			no change
LBA			no change

A SET MAX SET PASSWORD command shall previously have been successfully completed. This command is not immediately preceded by a READ NATIVE MAX ADDRESS command. If this command is immediately preceded by a READ NATIVE MAX ADDRESS command, it is interpreted as a SET MAX ADDRESS command. The SET MAX FREEZE LOCK command sets the device to Set_Max_Frozen state. After command completion any subsequent SET MAX commands are rejected.

Commands disabled by SET MAX FREEZE LOCK are:

- SET MAX ADDRESS
- SET MAX SET PASSWORD
- SET MAX LOCK
- SET MAX UNLOCK

11.8.32 SET MAX ADDRESS EXT (37h)

COMMAND CODE		0 0 1 1 0 1 1 1	REGISTER	
REGISTER SETTING			NORMAL COMPLETION	
DR		drive no.	no change	
LBA	Current	Max LBA(7:0)	HOB=0	no change
Low	Previous	Max LBA(31:24)	HOB=1	no change
LBA	Current	Max LBA(15:8)	HOB=0	no change
Mid	Previous	Max LBA(39:32)	HOB=1	no change
LBA	Current	Max LBA(23:16)	HOB=0	no change
High	Previous	Max LBA(47:40)	HOB=1	no change
SC	Current	00 _H / 01 _H	HOB=0	no change
	Previous	reserved	HOB=1	no change
FT	Current	reserved	HOB=0	no change
	Previous	reserved	HOB=1	no change

This command specifies the the maximum address in a range of actual drive capacity. If the address exceeding the set value is accessed , “ ABORT ERROR “ error will be reported. This set value affects the values of WORD 60, 61, 100-103 of IDENTIFY DEVICE command.

This command shall be immediately preceded by Read Native Max Address EXT command. Otherwise, it will be terminated with “ ABORT ERROR ” .

If this command is issued twice with a volatile bit set to 1 after power-up or hardware reset, “ID Not Found error” will be reported.

If a host protected area has been established by a SET MAX ADDRESS command, this command will be terminated with “ ABORT ERROR ” .

Volatile bit (SC register bit 0) :

If this command is issued with a volatile bit set to 1, the set value of this command is valid after power-up or hardware reset.

If this command is issued with a volatile bit cleared to 0, the set value of this command shall be cleared after hard reset or power-on and the maximam value shall be the last value with a volatile bit set to 1.

11.8.33 Read Native Max Address (F8h)

COMMAND CODE		1 1 1 1 1 0 0 0	REGISTER	
REGISTER SETTING			NORMAL COMPLETION	
DR		DRIVE No.	no change	
CY			maximum cylinder number	
HD			maximum head number	
SN			maximum sector number	
LBA			maximum LBA	

This command sets the maximum address in CY, HD, SN register. If LBA (DRV / HD register bit6) is set to 1, the maximum address shall be LBA value.

If the 48-bit native max address is greater than 268,435,455, the Read Native Max Address command shall return a maximum value of 268,435,454.

11.8.34 Read Native Max Address EXT (27h)

COMMAND CODE		0 0 1 0 0 1 1 1	REGISTER		
REGISTER SETTING			NORMAL COMPLETION		
DR		drive no.	no change		
LBA	Current		HOB=0	Max LBA(7:0)	
Low	Previous		HOB=1	Max LBA(31:24)	
LBA	Current		HOB=0	Max LBA(15:8)	
Mid	Previous		HOB=1	Max LBA(39:32)	
LBA	Current		HOB=0	Max LBA(23:16)	
High	Previous		HOB=1	Max LBA(47:40)	
SC	Current		HOB=0	no change	
	Previous		HOB=1	no change	
FT	Current		reserved	HOB=0	no change
	Previous		reserved	HOB=1	no change

This command sets the maximum address (LBA value).

11.8.35 Set Features (EFh)

COMMAND CODE	1 1 1 0 1 1 1 1	REGISTER
REGISTER SETTING		NORMAL COMPLETION
DR	DRIVE No.	no change
CY		no change
HD		no change
SN		no change
SC	Mode Selection for Data Transfer(*2)	no change
FT	Features(*1)	no change

(*1) Features: FT register defines following selections.

02H	Enable write cache feature
03H	Select data transfer mode
05H	Enable advanced power management
55H	Disable read look-ahead feature
66H	Disable reverting to power on defaults by soft reset
82H	Disable write cache feature
85H	Disable advanced power management
AAH	Enable read look-ahead feature
CCH	Enable reverting to power on defaults by soft reset
others	Invalid (reporting with Aborted Command Error)

(*2) Mode selection for data transfer is specified in sector count register. Upper 5 bits show transfer mode and lower 3 bits show mode figure.

PIO default transfer mode	00000 000
PIO default transfer mode, disable IORDY	00000 001
PIO flow control transfer mode nnn	00001 nnn
Multiword DMA mode nnn	00100 nnn
Ultra DMA mode nnn	01000 nnn
Reserved	10000 nnn

PIO default mode is mode 4 flow control. DMA default mode is Multiword DMA mode 2.

The level of Advanced Power Management function is set in Sector count register.

C0h-FEh Mode0 (Power save up to Low Power Idle)
 80h-BFh Mode1 (Power save up to Low Power Idle)
 01h-7Fh Mode2 (Power save up to Standby)
 00h,FFh Aborted

Transition time of power save is changed dynamically in Mode1 and Mode2 due to Adaptive power control function. The function level is set to Mode1 when Advanced Power Management function is disabled.

If FT register has any other value, the drive rejects the command with Abort Command error.

Default settings after power on or hard reset are:

Data transfer mode of Multiword DMA mode 2, PIO mode 4 flow control,
 4 bytes ECC, look-ahead read enabled, write cache enabled, advanced power management enabled,
 READ/WRITE Multiple command enabled (16 sectors)
 and reverting to power on defaults by soft reset disabled.

11.8.36 SECURITY SET PASSWORD (F1h)

COMMAND CODE	1 1 1 1 0 0 0 1	REGISTER
REGISTER SETTING		NORMAL COMPLETION
DR	DRIVE No.	no change
CY		no change
HD		no change
SN		no change
SC		no change
FT		no change

This command requests a transfer of a sector of data from the host including the information specified in the table below. The function of this command is decided by the transferred data. The revision code field is returned in the IDENTIFY DEVICE word 92. The valid revision codes are 0001h through FFFEh. A value of 0000h or FFFFh indicated that the Master Password Revision Code is not supported.

Security Set Password information

Word	Content
0	Control word Bits 15-9 Reserved Bits 8 Security level 0=High 1=Maximum Bits 7-1 Reserved Bit 0 Identifier 0=set user password 1=set master password
1-16	Password (32 bytes)
17	Master Password Revision Code (valid if word 0 bit 0 = 1)
18-255	Reserved

The settings of the identifier and security level bits interact as shown in the table below.

Identifier and security level

Identifier	Level	Command result
User	High	The password supplied with the command will be saved as the new user password. The lock function will be enabled by the next power-on. The drive can then be unlocked by either the user password or the previously set master password.
Master	High	This combination will set a master password but will not enable the lock function. The security level is not changed. Master password revision code set to the value in Master Password Revision Code field.
User	Maximum	The password supplied with the command will be saved as the new user password. The lock function will be enabled by the next power-on. The drive can only be unlocked by the user password. The master password previously set is still stored in the drive but will not be used to unlock the drive.
Master	Maximum	This combination will set a master password but will not enable the lock function. The security level is not changed. Master password revision code set to the value in Master Password Revision Code field.

11.8.37 SECURITY UNLOCK (F2h)

COMMAND CODE	1 1 1 1 0 0 1 0	REGISTER
REGISTER SETTING		NORMAL COMPLETION
DR	DRIVE No.	no change
CY		no change
HD		no change
SN		no change
SC		no change
FT		no change

This command requests the host to transfer a sector of data including ones described in the table below .

Security Unlock Information

Word	Content
0	Control word Bit 15-1 Reserved Bit 0 Identifier 0=compare user password 1=compare master password
1-16	Password (32 bytes)
17-255	Reserved

If the Identifier bit is set to master and the drive is in high security level, then the supplied password will be compared with the stored master password. If the drive is in maximum security level, then the SECURITY UNLOCK command will be rejected.

If the Identifier bit is set to user, the drive compares the supplied password with the stored user password. If the drive fails in comparing passwords, then the drive returns an abort error to the host and decrements the unlock counter. This counter is initially set to five and will be decremented for each mismatched passwords when SECURITY UNLOCK is issued and the drive is locked. When this counter is zero, SECURITY UNLOCK and SECURITY ERASE UNIT commands are aborted until the next power-on reset or hard reset. SECURITY UNLOCK commands issued when the drive is unlocked have no effect on the unlock counter.

11.8.38 SECURITY ERASE PREPARE (F3h)

COMMAND CODE	1 1 1 1 0 0 1 1	REGISTER
REGISTER SETTING		NORMAL COMPLETION
DR	DRIVE No.	no change
CY		no change
HD		no change
SN		no change
SC		no change
FT		no change

The SECURITY ERASE PREPARE command must be issued immediately before the SECURITY ERASE UNIT command to enable the drive erase and unlock. This command can prevent accidental erasure of the drive.

11.8.39 SECURITY ERASE UNIT (F4h)

COMMAND CODE		1 1 1 1 0 1 0 0	REGISTER
REGISTER SETTING			NORMAL COMPLETION
DR	DRIVE No.		no change
CY			no change
HD			no change
SN			no change
SC			no change
FT			no change

This command must be issued immediately after the SECURITY ERASE PREPARE command.

This command requests to transfer a sector of data from the host including the data specified in the following table. If the password does not match, the drive rejects the command with an Aborted command error.

Security Erase Unit Information

Word	Content
0	Control word Bit 15-1 Reserved Bit 0 Identifier 0=compare user password 1=compare master password
1-16	Password (32 bytes)
17-255	Reserved

The SECURITY ERASE UNIT command erases all user data. The SECURITY ERASE PREPARE command must be completed immediately prior to the SECURITY ERASE UNIT command, otherwise, the SECURITY ERASE UNIT command shall be aborted..

This command disables the drive lock function, however, the master password is still stored internally within the drive and may be reactivated later when a new user password is set.

11.8.40 SECURITY FREEZE LOCK (F5h)

COMMAND CODE		1 1 1 1 0 1 0 1	REGISTER
REGISTER SETTING			NORMAL COMPLETION
DR	DRIVE No.		no change
CY			no change
HD			no change
SN			no change
SC			no change
FT			no change

The SECURITY FREEZE LOCK allows the drive to enter frozen mode. After the completion of this command, any other commands that update the drive lock functions are rejected. The drive recovers from the frozen mode by power-on reset or hard reset. If SECURITY FREEZE LOCK is issued when the drive is in frozen mode, the drive executes the command and remains in frozen mode.

Following commands are rejected when the drive is in SECURITY FREEZE LOCK mode.

- SECURITY SET PASSWORD
- SECURITY UNLOCK
- SECURITY DISABLE PASSWORD
- SECURITY ERASE PREPARE
- SECURITY ERASE UNIT

11.8.41 SECURITY DISABLE PASSWORD (F6h)

COMMAND CODE	1 1 1 1 0 1 1 0	REGISTER
REGISTER SETTING		NORMAL COMPLETION
DR	DRIVE No.	no change
CY		no change
HD		no change
SN		no change
SC		no change
FT		no change

This command can be executed only when the drive is in unlocked mode. When the drive is in locked mode, the drive rejects the command with an Aborted command error.

The SECURITY DISABLE PASSWORD command requests a transfer of a single sector of data from the host including the information specified in the following table. Then the drive checks the transferred password. If the user password or the Master password match the given password, the drive disables the lock function. This command does not change the Master password which may be reactivated later by setting a user password.

Security Disable Information

Word	Content
0	Control word Bit 15-1 Reserved Bit 0 Identifier 0=compare user password 1=compare master password
1-16	Password (32 bytes)
17-255	Reserved

11.8.42 SMART Function Set (B0h)

This command has a number of separate functions which can be selected via the Feature Register when the command is issued. The subcommands and their respective codes are listed below.

Subcommand	Code
SMART READ ATTRIBUTE VALUES	D0h
SMART READ ATTRIBUTE THRESHOLDS	D1h
SMART ENABLE/DISABLE AUTOSAVE	D2h
SMART SAVE ATTRIBUTE VALUES	D3h
SMART EXECUTE OFF-LINE IMMEDIATE	D4h
SMART READ LOG SECTOR	D5h
SMART WRITE LOG SECTOR	D6h
SMART ENABLE OPERATIONS	D8h
SMART DISABLE OPERATIONS	D9h
SMART RETURN STATUS	DAh
SMART ENABLE/DISABLE AUTOMATIC OFF-LINE	DBh

11.8.42.1 SMART Read Attribute values

COMMAND CODE		1 0 1 1 0 0 0 0	REGISTER
		REGISTER SETTING	NORMAL COMPLETION
DR	DRIVE No.		no change
CY	C24Fh		no change
HD			no change
SN			no change
SC			
FT	D0h		no change

This command transfers SMART data as 512 byte data. Upon receipt of this command, the drive sets BSY, sets the SMART data on the buffer. Then, it sets DRQ, resets BSY, issue an interrupt to report that the drive is ready to transfer data.

Byte	Description
0-1	Data structure revision number
2-361	1st-30th Individual attribute data
362	Off-line data collection status
363	Self-test execution status
364-365	Total time in seconds to complete off-line data collection activity
366	Reserved
367	Off-line data collection capability
368-369	SMART capability
370	Error logging capability 7=1 Reserved 0 1= Device error logging supported
371	Self-test Failure Checkpoint
372	Short self-test routine recommended polling time (in minutes)
373	Extended self-test routine recommended polling time (in minutes)
374-510	Reserved
511	Data structure Checksum

BYTE 0-1: Data structure revision number
0010h is set

BYTE 2-361: Individual attribute data

The following table defines 12BYTE data for each Attribute data.

Byte	Description
0	Attribute ID number 01 - FFh
1-2	Status flag bit 0 (pre-failure/advisory bit) bit 0 = 0: If attribute value is less than the threshold, the drive is in advisory condition. Product life period may expired. bit 0 = 1: If attribute value is less than the threshold, the drive is in pre-failure condition. The drive may have failure. bit 1 (on-line data collection bit) bit 1= 0: Attribute value will be changed during off-line data collection operation. bit 1= 1: Attribute value will be changed during normal operation. bit 2 (Performance Attribute bit) bit 3 (Error rate attribute bit) bit 4 (Event Count Attribute bit) bit 5 (Self-Preserving Attribute bit) bit 6-15 Reserved
3	Attribute value 01h-FDh *1 00h, FEh, FFh = Not in use 01h = Minimum value 64h = Initial value Fdh = Maximum value
4	Worst Ever normalized Attribute Value (valid values from 01h-FEh)
5-10	Raw Attribute Value Attribute specific raw data (FFFFFFFh - reserved as saturated value)
11	Reserved (00h)

*1 For ID=199 CRC Error Count
Initial value = C8h

ID	Attribute Name
0	Indicates that entry in the data structure is not used
1	Read Error Rate
2	Throughput Performance
3	Spin Up Time
4	Start/Stop Count
5	Reallocated Sector Count
7	Seek Error Rate
8	Seek Time performance
9	Power-On hours Count
10	Spin Retry Count
12	Drive Power Cycle Count
192	Power-off Retract Count
193	Load Cycle Count
194	Temperature
196	Re-allocated Sector Event
197	Current Pending sector Count
198	Off-Line Scan Uncorrectable Sector Count
199	CRC Error Count
220	Disk Shift
222	Loaded Hours
223	Load Retry Count
224	Load Friction
226	Load in Time
240	Write Head

BYTE 362: Off-line data collection status

Value	Definition
00h or 80h	Off-line data collection activity was never started.
01h	Reserved
02h or 82h	Off-line data collection activity was completed without error.
03h or 83h	Off-line activity in progress.
04h or 84h	Off-line data collection activity was suspended by an interrupting command from host.
05h or 85h	Off-line data collection activity was aborted by an interrupting command from host.
06h or 86h	Off-line data collection activity was aborted by the device with a fatal error.
07h-FFh	Reserved

BYTE 363: Self-test execution status

The self-test execution status byte reports the execution status of the self-test routine.

Bits 0-3 (Percent Self-Test Remaining) The value in these bits indicates an approximation of the percent of the self-test routine remaining until completion in ten percent increments. Valid values are 0 through 9. A value of 0 indicates the self-test routine is complete. A value of 9 indicates 90% of total test time remaining.

Bits 4-7 (Self-test Execution Status) The value in these bits indicates the current Self-test Execution Status.

Self-test execution status values

Value	Description
0	The previous self-test routine completed without error or no self-test has ever been run
1	The self-test routine was aborted by the host
2	The self-test routine was interrupted by the host with a hard or soft reset
3	A fatal error or unknown test error occurred while the device was executing its self-test routine and the device was unable to complete the self-test routine.
4	The previous self-test completed having a test element that failed and the test element that failed is not known.
5	The previous self-test completed having the write element or the electrical element of the test failed.
6	The previous self-test completed having the servo (and/or seek) test element of the test failed.
7	The previous self-test completed having the read element of the test failed.
8-14	Reserved.
15	Self-test routine in progress.

BYTE 364-365: Total time

The time for off-line data collection operation (sec.)

BYTE 366: Reserve

BYTE 367: Off-line data collection capability

bit 0 (Execute off-line immediate implemented bit)

bit0 = 1 SMART EXECUTE OFF-LINE IMMEDIATE command supported.

bit0 = 0 SMART EXECUTE OFF-LINE IMMEDIATE command NOT supported

This bit is set to 1

bit 1 (enable/disable automatic off-line implemented bit)

bit0 = 1 SMART ENABLE/DISABLE AUTOMATIC OFF-LINE command supported.

bit0 = 0 SMART ENABLE/DISABLE AUTOMATIC OFF-LINE command NOT supported

This bit is set to 1

bit 2 (abort/restart off-line by host)

bit2 = 1 If another command is issued, off-line data collection operation is aborted.

bit2 = 0 If another command is issued, off-line data collection operation is interrupted and then the operation will be continued.

bit 3 (off-line read scanning implemented bit)

If this bit is cleared to zero, the device does not support off-line read scanning. If this bit is set to one, the device supports off-line read scanning. This bit is set to 1.

bit 4 (self-test implemented bit)

If this bit is cleared to zero, the device does not implement the Short and Extended self-test routines. If this bit is set to one, the device implements the Short and Extended self-test routines. This bit is set to 1.

bits 5 (reserved).

This bit is set to 0.

bits 6 (Selective self-test implemented bit)

If this bit is cleared to zero, the device does not implement the Selective self-test routine. If this bit is set to one, the device implements the Selective self-test routine. This bit is set to 1.

bits 7 (reserved).

This bit is set to 0.

BYTE 368-369: SMART capability

bit 0 (power mode SMART data saving capabilities bit)

bit0 = 1 SMART data is saved before Power save mode changes.

bit0 = 0 SMART data is NOT saved before Power save mode changes.

This bit is set to 1

bit 1 (SMART data autosave after event capability bit)

This bit is fixed to 1

bit 2-15 Reserved

BYTE 370 Error logging capability

BYTE 371 Self-test Failure Checkpoint

This byte reports the checkpoint when previous self-test failed.

BYTE 372-373: Self-test routine recommended polling time

The self-test routine recommended polling time is equal to the number of minutes that is the minimum recommended time before which the host should first poll for test completion status. Actual test time could be several times this value. Polling before this time could extend the self-test execution time or abort the test depending on the state of bit 2 of the off-line data capability bits.

BYTE 374-510: Reserved

BYTE 511: Data structure checksum

Checksum of the first 511 byte

11.8.42.2 SMART Read Attribute thresholds

COMMAND CODE		1 0 1 1 0 0 0 0	REGISTER
		REGISTER SETTING	NORMAL COMPLETION
DR		DRIVE No.	no change
CY		C24Fh	no change
HD			no change
SN			no change
SC			
FT		D1h	no change

This command transfers attribute thresholds of the drive as 512 byte data. Upon receipt of the command, the drive sets BSY, sets SMART data on the buffer, then, sets DRQ, resets BSY and issues an interrupt to report to the host that data transfer is ready.

Byte	Descriptions
0-1	Data structure revision number
2-361	1st-30th Individual attribute threshold data
362-510	Reserved
511	Data structure checksum

BYTE 0-1: Data structure revision number
The value for this byte is 0010h.

BYTE 2-361: Individual attribute threshold data
Individual attribute threshold data consists of 12 byte data. (See the following fig.)

Byte	Description
0	Attribute ID number 01h - FFh
1	Attribute Threshold 00h= Always passed 01h= Minimum value FDh= Maximum value FEh, FFh= Not in use
2-11	Reserved

BYTE 362-510: Reserved

BYTE 511: Data structure checksum
The checksum of the first 511 byte.

11.8.42.3 SMART Enable Disable Attribute Autosave

COMMAND CODE	1 0 1 1 0 0 0 0	REGISTER
REGISTER SETTING		NORMAL COMPLETION
DR	DRIVE No.	no change
CY	C24Fh	no change
HD		no change
SN		no change
SC	00h/F1h	no change
FT	D2h	no change

This command enables and disables the attribute autosave function within the drive. This command allow the drive to automatically save its updated attribute values to the attribute data sector at mode transition or cause the autosave feature to be disabled. The state of the attribute autosave feature (either enabled or disabled) will be preserved by the drive across power cycles.

A value of zero written by the host into the drive's Sector Count register before issuing this command may disable this function. Disabling this feature does not preclude the drive from saving attribute values to the attribute data sector during other normal save operations.

A value of F1h written by the host into the drive's Sector Count register before issuing this command will cause this function to be enabled. Any other non-zero value written by the host into this register before issuing this command will not change the state of the attribute autosave feature.

Upon receipt of the command from the host, the drive sets BSY, enables or disables the autosave function, clears BSY and asserts INTRQ.

11.8.42.4 SMART Save Attribute Values

COMMAND CODE	1 0 1 1 0 0 0 0	REGISTER
REGISTER SETTING		NORMAL COMPLETION
DR	DRIVE No.	no change
CY	C24Fh	no change
HD		no change
SN		no change
SC		no change
FT	D3h	no change

This command immediately saves changed attribute values. Upon receipt of the command, the drive sets BSY, saves the attribute values, clears BSY and issues an interrupt.

11.8.42.5 SMART Execute Off-line Immediate

COMMAND CODE	1 0 1 1 0 0 0 0	REGISTER
REGISTER SETTING		NORMAL COMPLETION
DR	DRIVE No.	no change
CY	C24Fh	no change
HD		no change
SN	Subcommand specific	no change
SC		no change
FT	D4h	no change

This command causes the device to immediately initiate the activities that collect SMART data in an off-line mode and then save this data to the device's non-volatile memory, or execute a self-diagnostic test routine in either captive or off-line mode.

The sector Number register will be set to specify the operation to be executed.

SMART EXECUTE OFF-LINE IMMEDIATE Sector Number register values

Value	Description of subcommand to be executed
0	Execute SMART off-line routine immediately in off-line mode
1	Execute SMART Short self-test routine immediately in off-line mode
2	Execute SMART Extended self-test routine immediately in off-line mode
3	Reserved
4	Execute SMART Selective self-test routine immediately in off-line mode
5-126	Reserved
127	Abort off-line mode self-test routine
128	Reserved
129	Execute SMART Short self-test routine immediately in captive mode
130	Execute SMART Extended self-test routine immediately in captive mode
131	Reserved
132	Execute SMART Selective self-test routine immediately in captive mode
133-255	Reserved

11.8.42.5.1 Off-line mode

The following describes the protocol for executing a SMART EXECUTE OFF-LINE IMMEDIATE subcommand routine (including a self-test routine) in the off-line mode.

- The device executes command completion before executing the subcommand routine.
- After clearing BSY to zero and setting DRDY to one after receiving the command, the device will not set BSY nor clear DRDY during execution of the subcommand routine.
- If the device is in the process of performing the subcommand routine and is interrupted by any new command from the host except a SLEEP, SMART DISABLE OPERATIONS, SMART EXECUTE OFF-LINE IMMEDIATE, STANDBY IMMEDIATE or IDLE IMMEDIATE command, the device suspends or aborts the subcommand routine and service the host within two seconds after receipt of the new command. After servicing the interrupting command from the host the device may re-initiate or resume the subcommand routine without any additional commands from the host.
- If the device is in the process of performing a subcommand routine and is interrupted by a SLEEP command from the host, the device will suspend or abort the subcommand routine and execute the SLEEP command. If the device is in the process of performing any self-test routine and is interrupted by a SLEEP command from the host, the device will abort the subcommand routine and execute the SLEEP command.

- e) If the device is in the process of performing the subcommand routine and is interrupted by a SMART DISABLE OPERATIONS command from the host, the device will abort the subcommand routine and service the host within two seconds after receipt of the command.
- f) If the device is in the process of performing the subcommand routine and is interrupted by a SMART EXECUTE OFF-LINE IMMEDIATE command from the host, the device will abort the subcommand routine and service the host within two seconds after receipt of the command. The device will then service the new SMART EXECUTE OFF-LINE IMMEDIATE subcommand.
- g) If the device is in the process of performing the subcommand routine and is interrupted by a STANDBY IMMEDIATE or IDLE IMMEDIATE command from the host, the device will suspend or abort the subcommand routine, and service the host within two seconds after receipt of the command. After receiving a new command that causes the device to exit a power saving mode, the device will initiate or resume the subcommand routine without any additional commands from the host unless these activities were aborted by the host.
- h) While the device is performing the subcommand routine it will not automatically change power states (e.g., as a result of its Standby timer expiring).

If an error occurs while a device is performing a self-test routine the device may discontinue the testing and place the test results in the Self-test execution status byte.

11.8.42.5.2 Captive mode

When executing a self-test in captive mode, the device sets BSY to one and executes the self-test routine after receipt of the command. At the end of the routine the device places the results of this routine in the Self-test execution status byte and executes command completion. If an error occurs while a device is performing the routine the device may discontinue its testing, place the results of this routine in the Self-test execution status byte, and complete the command.

11.8.42.5.3 SMART off-line routine

This routine will only be performed in the off-line mode. The results of this routine are placed in the Off-line data collection status byte.

11.8.42.5.4 SMART Short self-test routine

Depending on the value in the Sector Number register, this self-test routine may be performed in either the captive or the off-line mode. This self-test routine should take on the order of ones of minutes to complete.

11.8.42.5.5 SMART Extended self-test routine

Depending on the value in the Sector Number register, this self-test routine may be performed in either the captive or the off-line or mode. This self-test routine should take on the order of tens of minutes to complete.

11.8.42.5.6 SMART Selective self-test routine

When the value in the LBA Low register is 4 or 132, the Selective self-test routine shall be performed. This self-test routine shall include the initial tests performed by the Extended self-test routine plus a selectable read scan. The host shall not write the Selective self-test log while the execution of a Selective self-test command is in progress.

The user may choose to do read scan only on specific areas of the media. To do this, user shall set the test spans desired in the Selective self-test log and set the flags in the Feature flags field of the Selective self-test log to indicate do not perform off-line scan. In this case, the test spans defined shall be read scanned in their entirety. The Selective self-test log is updated as the self-test proceeds indicating test progress. When all specified test spans have been completed, the test is terminated and the appropriate self-test execution status is reported in the SMART READ DATA response depending on the occurrence of errors. The following figure shows an example of a Selective self-test definition with three test spans defined. In this example, the test terminates when all three test spans have been scanned.

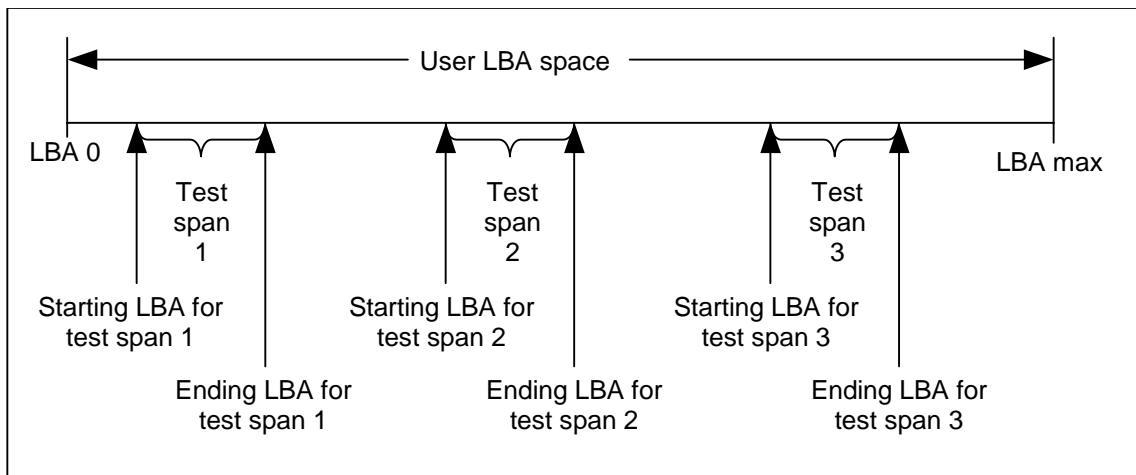

Selective self-test test span example

After the scan of the selected spans described above, a user may wish to have the rest of media read scanned as an off-line scan. In this case, the user shall set the flag to enable off-line scan in addition to the other settings. If an error occurs during the scanning of the test spans, the error is reported in the self-test execution status in the SMART READ DATA response and the off-line scan is not executed. When the test spans defined have been scanned, the device shall then set the off-line scan pending and active flags in the Selective self-test log to one, the span under test to a value greater than five, the self-test execution status in the SMART READ DATA response to 00h, set a value of 03h in the off-line data collection status in the SMART READ DATA response and shall proceed to do an off-line read scan through all areas not included in the test spans. This off-line read scan shall be completed as rapidly as possible, no pauses between block reads, and any errors encountered shall not be reported to the host. Instead error locations may be logged for future reallocation. If the device is powered-down before the off-line scan is completed, the off-line scan shall resume when the device is again powered up. From power-up, the resumption of the scan shall be delayed the time indicated in the Selective self-test pending time field in the Selective self-test log. During this delay time the pending flag shall be set to one and the active flag shall be set to zero in the Selective self-test log. Once the time expires, the active flag shall be set to one, and the off-line scan shall resume. When the entire media has been scanned, the off-line scan shall terminate, both the pending and active flags shall be cleared to zero, and the off-line data collection status in the SMART READ DATA response shall be set to 02h indicating completion.

During execution of the Selective self-test, the self-test execution time byte in the Device SMART Data Structure may be updated but the accuracy may not be exact because of the nature of the test span segments. For this reason, the time to complete off-line testing and the self-test polling times are not valid. Progress through the test spans is indicated in the selective self-test log.

A hardware or software reset shall abort the Selective self-test except when the pending bit is set to one in the Selective self-test log (see 11.8.42.6.5). The receipt of a SMART EXECUTE OFF-LINE IMMEDIATE command with 0Fh, Abort off-line test routine, in the LBA Low register shall abort Selective self-test regardless of where the device is in the execution of the command. If a second self-test is issued while a selective self-test is in progress, the selective self-test is aborted and the newly requested self-test is executed.

11.8.42.6 SMART Read Log Sector

COMMAND CODE		1 0 1 1 0 0 0 0	REGISTER
REGISTER SETTING			NORMAL COMPLETION
DR	DRIVE No.		no change
CY	C24Fh		no change
HD			no change
SN	Log Sector Address		no change
SC	Number of sectors to read		00h
FT	D5h		no change

This command returns the indicated log sector contents to the host.
Sector count -specifies the number of sectors to be read from the specified log. The log transferred by the drive shall start at the first sector in the specified log, regardless of the sector count requested.
Sector number indicates the log sector to be returned as described in the following Table.

Log Sector

Log sector address	Content	R/W
00h	Log directory	RO
01h	SMART error log	RO
02h	Comprehensive SMART error log	RO
03h	Extended comprehensive SMART error log	See Note
04h-05h	Reserved	RO
06h	SMART self-test log	RO
07h	Extended SMART self-test log	See Note
08h	Reserved	RO
09h	Selective self-test log	RO
0Ah-7Fh	Reserved	RO
80h-9Fh	Host vendor specific	R/W
A0h-FFh	Reserved	VS

Key –
RO –Log is read only by the host.
R/W –Log is read or written by the host.
VS –Log is vendor specific thus read/write ability is vendor specific.

NOTE - Log addresses 03h and 07h are used by the READ LOG EXT and WRITE LOG EXT commands. If these log addresses are used with the SMART READ LOG command, the device shall return command aborted.

11.8.42.6.1 SMART log directory

The following table defines the 512 bytes that make up the SMART Log Directory. The SMART Log Directory is SMART Log address zero, and is defined as one sector long.

SMART Log Directory

Byte	Descriptions
0-1	SMART Logging Version
2	Number of sectors in the log at log address 1
3	Reserved
4	Number of sectors in the log at log address 2
5	Reserved
...	...
510	Number of sectors in the log at log address 255
511	Reserved

The value of the SMART Logging Version word is set to 01h. Then the drive supports multi-sector SMART logs. In addition, if the drive supports multi-sector logs, then the logs at log addresses 80-9Fh shall each be defined as 16 sectors long.

11.8.42.6.2 Summary error log sector

The following Table defines the 512 bytes that make up the SMART summary error log sector.

SMART summary error log sector

Byte	Descriptions
0	SMART error log version
1	Error log index
2-91	First error log data structure
92-181	Second error log data structure
182-271	Third error log data structure
272-361	Fourth error log data structure
362-451	Fifth error log data structure
452-453	Device error count
454-510	Reserved
511	Data structure checksum

11.8.42.6.2.1 Error log version

The value of the SMART error log version byte is set to 01h.

11.8.42.6.2.2 Error log data structure

An error log data structure will be presented for each of the last five errors reported by the device. These error log data structure entries are viewed as a circular buffer. That is, the first error will create the first error log data structure; the second error, the second error log structure; etc. The sixth error will create an error log data structure that replaces the first error log data structure; the seventh error replaces the second error log structure, etc. The error log pointer indicates the most recent error log structure. If fewer than five errors have occurred, the unused error log structure entries will be zero filled. The following table describes the content of a valid error log data structure.

Error log data structure

Byte	Descriptions
n –n+11	First command data structure
N+12 –n+23	Second command data structure
N+24 –n+35	Third command data structure
N+36 – n+47	Fourth command data structure
N+48 – n+59	Fifth command data structure
N+60 – n+89	Error data structure

11.8.42.6.2.3 Command data structure

The fifth command data structure will contain the command or reset for which the error is being reported. The fourth command data structure should contain the command or reset that preceded the command or reset for which the error is being reported, the third command data structure should contain the command or reset preceding the one in the fourth command data structure, etc. If fewer than four commands and resets preceded the command or reset for which the error is being reported, the unused command data structures will be zero filled, for example, if only three commands and resets preceded the command or reset for which the error is being reported, the first command data structure will be zero filled. In some devices, the hardware implementation may preclude the device from reporting the commands that preceded the command for which the error is being reported or that preceded a reset. In this case, the command data structures are zero filled.

If the command data structure represents a command or software reset, the content of the command data structure will be as shown in the following Table.

Command data structure

Byte	Descriptions
n	Content of the Device Control register when the Command register was written.
n+1	Content of the Features register when the Command register was written.
n+2	Content of the Sector Count register when the Command register was written.
n+3	Content of the Sector Number register when the Command register was written.
n+4	Content of the Cylinder Low register when the Command register was written.
n+5	Content of the Cylinder High register when the Command register was written.
n+6	Content of the Device/Head register when the Command register was written.
n+7	Content written to the Command register.
n+8	Timestamp
n+9	Timestamp
n+10	Timestamp
n+11	Timestamp

Timestamp shall be the time since power-on in milliseconds when command acceptance occurred. This timestamp may wrap around.

11.8.42.6.2.4 Error data structure

The error data structure will contain the error description of the command for which an error was reported as described in the following table.

Error data structure

Byte	Descriptions
N	Reserved
n+1	Content of the Error register after command completion occurred.
n+2	Content of the Sector Count register after command completion occurred.
n+3	Content of the Sector Number register after command completion occurred.
n+4	Content of the Cylinder Low register after command completion occurred.
n+5	Content of the Cylinder High register after command completion occurred.
n+6	Content of the Device/Head register after command completion occurred.
n+7	Content written to the Status register after command completion occurred.
n+8 - n+26	Extended error information
n+27	State
n+28	Life timestamp (least significant byte)
n+29	Life timestamp (most significant byte)

Extended error information will be vendor specific.

State will contain a value indicating the state of the device when command was written to the Command register or the reset occurred as described in the following Table.

State field values

Value	State
x0h	Unknown
x1h	Sleep
x2h	Standby
x3h	Active/Idle with BSY cleared to zero
x4h	Executing SMART off-line or self-test
x5h-xAh	Reserved
xBh-xFh	Vendor unique
The value of x is vendor specific and may be different for each state.	

Sleep indicates the reset for which the error is being reported was received when the device was in the Sleep mode.

Standby indicates the command or reset for which the error is being reported was received when the device was in the Standby mode.

Active/Idle with BSY cleared to zero indicates the command or reset for which the error is being reported was received when the device was in the Active or Idle mode and BSY was cleared to zero.

Executing SMART off-line or self-test indicates the command or reset for which the error is being reported was received when the device was in the process of executing a SMART off-line or self-test.

Life timestamp will contain the power-on lifetime of the device in hours when command completion occurred.

11.8.42.6.2.5 Device error count

The device error count field will contain the total number of errors attributable to the device that have been reported by the device during the life of the device. These errors will include UNC errors, IDNF errors for which the address requested was valid, servo errors, write fault errors, etc. This count will not include errors attributed to the receipt of faulty commands such as commands codes not implemented by the device or requests with invalid parameters or invalid addresses. If the maximum value for this field is reached, the count will remain at the maximum value when additional errors are encountered and logged.

11.8.42.6.2.6 Data structure checksum

The data structure checksum is the two's complement of the sum of the first 511 bytes in the data structure. Each byte will be added with unsigned arithmetic, and overflow will be ignored. The sum of all 512 bytes will be zero when the checksum is correct. The checksum is placed in byte 511.

11.8.42.6.3 Comprehensive error log

The following defines the format of each of the sectors that comprise the SMART comprehensive error log. The SMART Comprehensive error log provides logging for 28-bit addressing only. For 48-bit addressing see 11.8.43.2 . The size of the SMART comprehensive error log is 51 sectors. All multi-byte fields shown in this structure follow the byte ordering described in 11.8.42.6.2.3 and 11.8.42.6.2.4. The comprehensive error log data structures shall include UNC errors, IDNF errors for which the address requested was valid, servo errors, write fault errors, etc. Comprehensive error log data structures shall not include errors attributed to the receipt of faulty commands such as command codes not supported by the device or requests with invalid parameters or invalid addresses.

Comprehensive error log

Byte	First sector	Subsequent sectors
0	SMART error log version	Reserved
1	Error log index	Reserved
2-91	First error log data structure	Data structure 5n+1
92-181	Second error log data structure	Data structure 5n+2
182-271	Third error log data structure	Data structure 5n+3
272-361	Fourth error log data structure	Data structure 5n+4
362-451	Fifth error log data structure	Data structure 5n+5
452-453	Device error count	Reserved
454-510	Reserved	Reserved
511	Data structure checksum	Data structure checksum

n is the sector number within the log. The first sector is sector zero

11.8.42.6.3.1 Error log version

The value of the error log version byte shall be set to 01h.

11.8.42.6.3.2 Error log index

The error log index indicates the error log data structure representing the most recent error. If there have been no error log entries, the error log index is set to zero. Valid values for the error log index are zero to 255.

11.8.42.6.3.3 Error log data structure

The error log is viewed as a circular buffer. The device may support from two to 51 error log sectors. When the last supported error log sector has been filled, the next error shall create an error log data structure that replaces the first error log data structure in sector zero. The next error after that shall create an error log data structure that replaces the second error log data structure in sector zero. The sixth error after the log has filled shall replace the first error log data structure in sector one, and so on.

The error log index indicates the most recent error log data structure. Unused error log data structures shall be filled with zeros.

The content of the error log data structure entries is defined in 11.8.42.6.2.2.

11.8.42.6.3.4 Device error count

The device error count field is defined in 11.8.42.6.2.5.

11.8.42.6.3.5 Data structure checksum

The data structure checksum is defined in 11.8.42.6.2.6.

11.8.42.6.4 Self-test log sector

The following Table defines the 512 bytes that make up the SMART self-test log sector.

Self-test log data structure

Byte	Descriptions
0-1	Self-test log data structure revision number
2-25	First descriptor entry
26-49	Second descriptor entry
.....
482-505	Twenty-first descriptor entry
506-507	Vendor specific
508	Self-test index
509-510	Reserved
511	Data structure checksum

11.8.42.6.4.1 Self-test log data structure revision number

The value of the self-test log data structure revision number is set to 0001h.

11.8.42.6.4.2 Self-test log descriptor entry

This log is viewed as a circular buffer. The first entry will begin at byte 2, the second entry will begin at byte 26, and so on until the twenty-second entry, that will replace the first entry. Then, the twenty-third entry will replace the second entry, and so on. If fewer than 21 self-tests have been performed by the device, the unused descriptor entries will be filled with zeroes.

The content of the self-test descriptor entry is shown in the following Table.

Self-test log descriptor entry

Byte	Descriptions
n	Content of the Sector Number
n+1	Content of the self-test execution status
n+2	Life timestamp (least significant byte).
n+3	Life timestamp (most significant byte).
n+4	Content of the self-test failure checkpoint
n+5	Failing LBA(least significant byte).
n+6	Failing LBA(next least significant byte).
n+7	Failing LBA(next most significant byte).
n+8	Failing LBA(most significant byte).
n+9 - n+23	Vendor specific.

Content of the Sector Number register will be the content of the Sector Number register when the nth self-test subcommand was issued.

Content of the self-test execution status byte will be the content of the self-test execution status byte when the nth self-test was completed

Life timestamp will contain the power-on lifetime of the device in hours when the nth self-test subcommand was completed.

Content of the self-test failure checkpoint byte will be the content of the self-test failure checkpoint byte when the nth self-test was completed.

The failing LBA will be the LBA of the uncorrectable sector that caused the test to fail. If the device encountered more than one uncorrectable sector during the test, this field will indicate the LBA of the first uncorrectable sector encountered. If the test passed or the test failed for some reason other than an uncorrectable sector, the value of this field is undefined.

11.8.42.6.4.3 Self-test index

The self-test index will point to the most recent entry. Initially, when the log is empty, the index will be set to zero. It will be set to one when the first entry is made, two for the second entry, etc., until the 22nd entry, when the index will be reset to one.

11.8.42.6.4.4 Data structure checksum

The data structure checksum is the two's complement of the sum of the first 511 bytes in the data structure. Each byte will be added with unsigned arithmetic, and overflow will be ignored. The sum of all 512 bytes is zero when the checksum is correct. The checksum is placed in byte 511.

11.8.42.6.5 Selective self-test log

The Selective self-test log is a log that may be both written and read by the host. This log allows the host to select the parameters for the self-test and to monitor the progress of the self-test. The following table defines the content of the Selective self-test log.

Selective self-test log

Byte	Description	Read/write
0-1	Data structure revision number	R/W
2-9	Starting LBA for test span 1	R/W
10-17	Ending LBA for test span 1	R/W
18-25	Starting LBA for test span 2	R/W
26-33	Ending LBA for test span 2	R/W
34-41	Starting LBA for test span 3	R/W
42-49	Ending LBA for test span 3	R/W
50-57	Starting LBA for test span 4	R/W
58-65	Ending LBA for test span 4	R/W
66-73	Starting LBA for test span 5	R/W
74-81	Ending LBA for test span 5	R/W
82-337	Reserved	Reserved
338-491	Vendor specific	Vendor specific
492-499	Current LBA under test	Read
500-501	Current span under test	Read
502-503	Feature flags	R/W
504-507	Vendor specific	Vendor specific
508-509	Selective self-test pending time	R/W
510	Reserved	Reserved
511	Data structure checksum	R/W

11.8.42.6.5.1 Data structure revision number

The value of the data structure revision number filed shall be 01h. This value shall be written by the host and returned unmodified by the device.

11.8.42.6.5.2 Test span definition

The Selective self-test log provides for the definition of up to five test spans. The starting LBA for each test span is the LBA of the first sector tested in the test span and the ending LBA for each test span is the last LBA tested in the test span. If the starting and ending LBA values for a test span are both zero, a test span is not defined and not tested. These values shall be written by the host and returned unmodified by the device.

11.8.42.6.5.3 Current LBA under test

The Current LBA under test field shall be written with a value of zero by the host. As the self-test progresses, the device shall modify this value to contain the beginning LBA of the 65,536 sector block currently being tested. When the self-test including the off-line scan between test spans has been completed, a zero value is placed in this field.

11.8.42.6.5.4 Current span under test

The Current span under test field shall be written with a value of zero by the host. As the self-test progresses, the device shall modify this value to contain the test span number of the current span being tested. If an off-line scan between test spans is selected, a value greater than five is placed in this field during the off-line scan. When the self-test including the off-line scan between test spans has been completed, a zero value is placed in this field.

11.8.42.6.5.5 Feature flags

The Feature flags define the features of Selective self-test to be executed (see following table).

Bit	Description
0	Vendor specific
1	When set to one, perform off-line scan after selective test.
2	Vendor specific
3	When set to one, off-line scan after selective test is pending.
4	When set to one, off-line scan after selective test is active.
5-15	Reserved.

Bit (1) shall be written by the host and returned unmodified by the device. Bits (4:3) shall be written as zeros by the host and the device shall modify them as the test progresses.

11.8.42.6.5.6 Selective self-test pending time

The selective self-test pending time is the time in minutes from power-on to the resumption of the off-line testing if the pending bit is set. At the expiration of this time, sets the active bit to one, and resumes the off-line scan that had begun before power-down.

11.8.42.6.5.7 Data structure checksum

The data structure checksum is the two's complement of the sum of the first 511 bytes in the data structure. Each byte will be added with unsigned arithmetic, and overflow will be ignored. The sum of all 512 bytes is zero when the checksum is correct. The checksum is placed in byte 511.

11.8.42.7 SMART Write Log Sector

COMMAND CODE	1 0 1 1 0 0 0 0	REGISTER
REGISTER SETTING		NORMAL COMPLETION
DR	DRIVE No.	no change
CY	C24Fh	no change
HD		no change
SN	Log Sector Address	no change
SC	Number of sectors to write	00h
FT	D6h	no change

This command writes an indicated number of 512 byte data sectors to the indicated log.

11.8.42.8 SMART Enable Operations

COMMAND CODE	1 0 1 1 0 0 0 0	REGISTER
REGISTER SETTING		NORMAL COMPLETION
DR	DRIVE No.	no change
CY	C24Fh	no change
HD		no change
SN		no change
SC		no change
FT	D8h	no change

This command enables access to all SMART capabilities of the drive. Prior to receipt of this command, Parameters for drive failure prediction are neither monitored nor saved by the drive. The state of SMART (either enabled or disabled) will be preserved by the drive across power cycles. Once enabled, the receipt of subsequent SMART ENABLE OPERATIONS commands don't affect any of the parameters for drive failure prediction.

Upon receipt of this command from the host, the drive sets BSY, enables SMART capabilities and functions, clears BSY and asserts INTRQ.

11.8.42.9 SMART Disable Operations

COMMAND CODE	1 0 1 1 0 0 0 0	REGISTER
REGISTER SETTING		NORMAL COMPLETION
DR	DRIVE No.	no change
CY	C24Fh	no change
HD		no change
SN		no change
SC		no change
FT	D9h	no change

This command disables all SMART capabilities within the drive including any and all timer functions related exclusively to this function. After receipt of this command the drive may disable all SMART operations. Parameters for drive failure prediction will no longer be monitored or saved by the drive. The state of SMART (either enabled or disabled) will be preserved by the drive across power cycles.

Upon receipt of the SMART DISABLE OPERATIONS command from the host, the drive sets BSY, disables SMART capabilities and functions, clears BSY and asserts INTRQ.

After receipt of this command by the drive, all other SMART commands, except for SMART ENABLE OPERATIONS, are disabled and invalid and will be aborted by the drive (including SMART DISABLE OPERATIONS commands) with an Aborted command error.

11.8.42.10 SMART Return Status

COMMAND CODE	1 0 1 1 0 0 0 0	REGISTER
REGISTER SETTING		NORMAL COMPLETION
DR	DRIVE No.	no change
CY	C24Fh	C24Fh/2CF4h
HD		no change
SN		no change
SC		no change
FT	DAh	no change

If an impending failure is not predicted, the drive sets the Cylinder Low register to 4Fh and the Cylinder High register to C2h. If an impending failure is predicted, the drive sets the Cylinder Low register to F4h and the Cylinder High register to 2Ch.

This command is used to communicate the reliability status of the drive to the host's request. Upon receipt of this command the drive sets BSY, saves any parameters monitored by the drive to non-volatile memory and checks the drive condition.

11.8.42.11 SMART Enable/Disable Automatic Off-line

COMMAND CODE	1 0 1 1 0 0 0 0	REGISTER
REGISTER SETTING		NORMAL COMPLETION
DR	DRIVE No.	no change
CY	C24Fh	no change
HD		no change
SN		no change
SC	00h/F8h	no change
FT	DBh	no change

This subcommand enables and disables the optional feature that causes the device to perform the set of off-line data collection activities that automatically collect attribute data in an off-line mode and then save this data to the device's non-volatile memory. This subcommand may either cause the device automatically initiate or resume performance of its off-line data collection activities; or this command may cause the automatic off-line data collection feature to be disabled.

A value of zero written by the host into the device's Sector Count register before issuing this subcommand will cause the feature to be disabled. Disabling this feature does not preclude the device from saving attribute values to non-volatile memory during some other normal operation such as during a power-on or power-off sequence or during an error recovery sequence.

A value of F8h written by the host into the device's Sector Count register before issuing this command will cause this feature to be enabled. Any other non-zero value written by the host into this register before issuing this subcommand is vendor specific.

Automatic off-line data collection is executed every 24 power-on hours.

11.8.43 Read Log EXT (2Fh)

COMMAND CODE		0 0 1 0 1 1 1 1		REGISTER	
		REGISTER SETTING		NORMAL COMPLETION	
DR		drive no.		no change	
LBA	Current	log address		HOB=0	Reserved
Low	Previous	Reserved		HOB=1	Reserved
LBA	Current	Sector offset(7:0)		HOB=0	Reserved
Mid	Previous	Sector offset(15:8)		HOB=1	Reserved
LBA	Current	Reserved		HOB=0	Reserved
High	Previous	Reserved		HOB=1	Reserved
SC	Current	sector count(7:0)		HOB=0	Reserved
	Previous	sector count(15:8)		HOB=1	Reserved
FT	Current	Reserved		HOB=0	no change
	Previous	Reserved		HOB=1	no change

This command returns the specified log to the host. The device shall interrupt for each DRQ block transferred.

Sector Count - Specifies the number of sectors to be read from the specified log. The log transferred by the drive shall start at the sector in the specified log at the specified offset, regardless of the sector count requested.

LBA Low - Specifies the log to be returned as described in the following Table.

LBA Mid - Specifies the first sector of the log to be read.

Log Sector

Log sector address	Content	R/W
00h	Log directory	RO
01h	SMART error log	See Note
02h	Comprehensive SMART error log	See Note
03h	Extended comprehensive SMART error log	RO
04h-05h	Reserved	-
06h	SMART self-test log	See Note
07h	Extended SMART self-test log	RO
08h	Reserved	-
09h	Selective self-test log	See Note
0Ah-7Fh	Reserved	-
80h-9Fh	Host vendor specific	R/W
A0h-FFh	Reserved	-

Key –
 RO –Log is read only by the host.
 R/W –Log is read or written by the host.

NOTE - Log addresses 01h,02,,06h and 09h are used by the SMART READ LOG command commands. If these log addresses are used with the READ LOG EXT command, the device shall return command aborted.

11.8.43.1 General Purpose Log Directory

The following table defines the 512 bytes that make up the General Purpose Log Directory.

General Purpose Log Directory

Byte	Descriptions
0-1	General Purpose Logging Version
2	Number of sectors in the log at log address 01h (7:0)
3	Number of sectors in the log at log address 01h (15:8)
4	Number of sectors in the log at log address 02h (7:0)
5	Number of sectors in the log at log address 02h (15:8)
...	
256	10h sectors in the log at log address 80h
257	00h sectors in the log at log address 80h
...	
510-511	Number of sectors in the log at log address FFh

The value of the General Purpose Logging Version word is 0001h.

The logs at log addresses 80-9Fh shall each be defined as 16 sectors long.

11.8.43.2 Extended Comprehensive SMART Error log

The following table defines the format of each of the sectors that comprise the Extended Comprehensive SMART error log. The size of the Extended Comprehensive SMART error log is 64 sectors. Error log data structures shall include UNC errors, IDNF errors for which the address requested was valid, servo errors, write fault errors, etc. Error log data structures shall not include errors attributed to the receipt of faulty commands such as command codes not implemented by the device or requests with invalid parameters or invalid addresses.

All 28-bit entries contained in the Comprehensive SMART log, defined under section 11.8.42.6.3, shall also be included in the Extended Comprehensive SMART error log with the 48-bit entries.

Extended Comprehensive SMART error log

Byte	First sector	Subsequent sectors
0	SMART error log version	Reserved
1	Reserved	Reserved
2	Error log index (7:0)	Reserved
3	Error log index (15:8)	Reserved
4-127	First error log data structure	Data structure 4n+1
128-251	Second error log data structure	Data structure 4n+2
252-375	Third error log data structure	Data structure 4n+3
376-499	Fourth error log data structure	Data structure 4n+4
500-501	Device error count	Reserved
502-510	Reserved	Reserved
511	Data structure checksum	Data structure checksum
n is the sector number within the log. The first sector is sector zero		

11.8.43.2.1 Error log version

The value of the SMART error log version byte is 01h.

11.8.43.2.2 Error log index

The error log index indicates the error log data structure representing the most recent error. If there have been no error log entries, the error log index is cleared to zero. Valid values for the error log index are zero to 255.

11.8.43.2.3 Extended Error log data structure

The error log is viewed as a circular buffer. When the last supported error log sector has been filled, the next error shall create an error log data structure that replaces the first error log data structure in sector zero. The next error after that shall create an error log data structure that replaces the second error log data structure in sector zero. The fifth error after the log has filled shall replace the first error log data structure in sector one, and so on.

The error log index indicates the most recent error log data structure. Unused error log data structures shall be filled with zeros.

The content of the error log data structure entries is defined in the following table.

Byte	Descriptions
n thru n+17	First command data structure
n+18 thru n+35	Second command data structure
n+36 thru n+53	Third command data structure
n+54 thru n+71	Fourth command data structure
n+72 thru n+89	Fifth command data structure
n+90 thru n+123	Error data structure

11.8.43.2.3.1 Command data structure

The fifth command data structure shall contain the command or reset for which the error is being reported. The fourth command data structure should contain the command or reset that preceded the command or reset for which the error is being reported, the third command data structure should contain the command or reset preceding the one in the fourth command data structure, etc. If fewer than four commands and resets preceded the command or reset for which the error is being reported, the unused command data structures shall be zero filled, for example, if only three commands and resets preceded the command or reset for which the error is being reported, the first command data structure shall be zero filled. In some devices, the hardware implementation may preclude the device from reporting the commands that preceded the command for which the error is being reported or that preceded a reset. In this case, the command data structures are zero filled. If the command data structure represents a command or software reset, the content of the command data structure shall be as shown in the following table. If the command data structure represents a hardware reset, the content of byte n shall be FFh, the content of bytes n+1 through n+13 are vendor specific, and the content of bytes n+14 through n+17 shall contain the timestamp.

Command data structure

Byte	Descriptions
n	Content of the Device Control register when the Command register was written.
N+1	Content of the Features register (7:0) when the Command register was written. (see note)
n+2	Content of the Features register (15:8) when the Command register was written.
N+3	Content of the Sector Count register (7:0) when the Command register was written.
N+4	Content of the Sector Count register (15:8) when the Command register was written.
N+5	Content of the LBA Low register (7:0) when the Command register was written.
N+6	Content of the LBA Low register (15:8) when the Command register was written.
N+7	Content of the LBA Mid register (7:0) when the Command register was written.
N+8	Content of the LBA Mid register (15:8) when the Command register was written.
N+9	Content of the LBA High register (7:0) when the Command register was written.
N+10	Content of the LBA High register (15:8) when the Command register was written.
N+11	Content of the Device/Head register when the Command register was written.
N+12	Content written to the Command register.
N+13	Reserved
n+14	Timestamp (least significant byte)
n+15	Timestamp (next least significant byte)
n+16	Timestamp (next most significant byte)
n+17	Timestamp (most significant byte)
NOTE - bits (7:0) refer to the most recently written contents of the register. Bits (15:8) refer to the contents of the register prior to the most recent write to the register.	

Timestamp shall be the time since power-on in milliseconds when command acceptance occurred. This timestamp may wrap around.

11.8.43.2.3.2 Error data structure

The error data structure shall contain the error description of the command for which an error was reported as described in the following table. If the error was logged for a hardware reset, the content of bytes n+1 through n+11 shall be vendor specific and the remaining bytes shall be as defined in the following table.

Error data structure

Byte	Descriptions
n	Reserved
n+1	Content of the Error register after command completion occurred.
N+2	Content of the Sector Count register (7:0) after command completion occurred. (see note)
n+3	Content of the Sector Count register (15:8) after command completion occurred. (see note)
n+4	Content of the LBA Low register (7:0) after command completion occurred.
N+5	Content of the LBA Low register (15:8) after command completion occurred.
N+6	Content of the LBA Mid register (7:0) after command completion occurred.
N+7	Content of the LBA Mid register (15:8) after command completion occurred.
N+8	Content of the LBA High register (7:0) after command completion occurred.
N+9	Content of the LBA High register (15:8) after command completion occurred.
N+10	Content of the Device/Head register after command completion occurred.
N+11	Content written to the Status register after command completion occurred.
N+12 through n+30	Extended error information
n+31	State
n+32	Life timestamp (least significant byte)
n+33	Life timestamp (most significant byte)
NOTE - bits (7:0) refer to the contents if the register were read with bit 7 of the Device Control register cleared to zero. Bits (15:8) refer to the contents if the register were read with bit 7 of the Device Control register set to one.	

State shall contain a value indicating the state of the device when the command was written to the Command register or the reset occurred as described in the following table.

State field values

Value	State
x0h	Unknown
x1h	Sleep
x2h	Standby
x3h	Active/Idle with BSY cleared to zero
x4h	Executing SMART off-line or self-test
x5h-xFh	Reserved
The value of x is vendor specific and may be different for each state.	

Sleep indicates the reset for which the error is being reported was received when the device was in the Sleep mode.

Standby indicates the command or reset for which the error is being reported was received when the device was in the Standby mode.

Active/Idle with BSY cleared to zero indicates the command or reset for which the error is being reported was received when the device was in the Active or Idle mode and BSY was cleared to zero.

Executing SMART off-line or self-test indicates the command or reset for which the error is being reported was received when the device was in the process of executing a SMART off-line or self-test.

Life timestamp shall contain the power-on lifetime of the device in hours when command completion occurred.

11.8.43.2.4 Device error count

The device error count field shall contain the total number of errors attributable to the device that have been reported by the device during the life of the device. These errors shall include UNC errors, IDNF errors for which the address requested was valid, servo errors, write fault errors, etc. This count shall not include errors attributed to the receipt of faulty commands such as commands codes not implemented by the device or requests with invalid parameters or invalid addresses. If the maximum value for this field is reached, the count shall remain at the maximum value when additional errors are encountered and logged.

11.8.43.2.5 Data structure checksum

The data structure checksum is the two's complement of the sum of the first 511 bytes in the data structure. Each byte shall be added with unsigned arithmetic, and overflow shall be ignored. The sum of all 512 bytes will be zero when the checksum is correct. The checksum is placed in byte 511.

11.8.43.3 Extended Self-test log sector

The following table defines the format of each of the sectors that comprise the Extended SMART Self-test log. The size of the self-test log is 1 sectors.

The Extended SMART self-test log sector shall support 48-bit and 28-bit addressing. All 28-bit entries contained in the SMART self-test log, defined under section 11.8.42.6.4 shall also be included in the Extended SMART self-test log with all 48-bit entries.

Extended Self-test log data structure

Byte	First sector	Subsequent sectors
0	Self-test log data structure revision number	Reserved
1	Reserved	Reserved
2	Self-test descriptor index (7:0)	Reserved
3	Self-test descriptor index (15:8)	Reserved
4-29	Descriptor entry 1	Descriptor entry 18n+1
30-55	Descriptor entry 2	Descriptor entry 18n+2
....
472-497	Descriptor entry 18	Descriptor entry 18n+18
498-499	Vendor specific	Vendor specific
500-510	Reserved	Reserved
511	Data structure checksum	Data structure checksum

n is the sector number within the log. The first sector is sector zero

This log is viewed as a circular buffer. The first entry will begin at byte 4, the second entry will begin at byte 30 and so on until the nineteenth entry, that will replace the first entry. Then, the twenty entry will replace the second entry, and so on. If fewer than 18 self-tests have been performed by the device, the unused descriptor entries will be filled with zeroes.

11.8.43.3.1 Self-test descriptor index

The Self-test descriptor index indicates the most recent self-test descriptor. If there have been no self-tests, the Self-test descriptor index is set to zero. Valid values for the Self-test descriptor index are zero to 18.

11.8.43.3.2 Self-test log data structure revision number

The value of the self-test log data structure revision number is 01h.

11.8.43.3.3 Extended Self-test log descriptor entry

The content of the self-test descriptor entry is shown in the following table..

Extended Self-test log descriptor entry

Byte	Descriptions
n	Content of the LBA Low register.
n+1	Content of the self-test execution status byte.
n+2	Life timestamp (least significant byte).
n+3	Life timestamp (most significant byte).
n+4	Content of the self-test failure checkpoint byte.
n+5	Failing LBA (7:0).
n+6	Failing LBA (15:8).
n+7	Failing LBA (23:16).
n+8	Failing LBA (31:24).
n+9	Failing LBA (39:32).
n+10	Failing LBA (47:40).
n+1 - n+23	Vendor specific.

Content of the LBA Low register shall be the content of the LBA Low register when the nth self-test subcommand was issued (see 11.8.42.5).

Content of the self-test execution status byte shall be the content of the self-test execution status byte when the nth self-test was completed (see 11.8.42.5).

Life timestamp shall contain the power-on lifetime of the device in hours when the nth self-test subcommand was completed.

Content of the self-test failure checkpoint byte may contain additional information about the self-test that failed.

The failing LBA shall be the LBA of the sector that caused the test to fail. If the device encountered more than one failed sector during the test, this field shall indicate the LBA of the first failed sector encountered. If the test passed or the test failed for some reason other than a failed sector, the value of this field is undefined.

11.8.43.3.4 Data structure checksum

The data structure checksum is the two's complement of the sum of the first 511 bytes in the data structure. Each byte shall be added with unsigned arithmetic, and overflow shall be ignored. The sum of all 512 bytes is zero when the checksum is correct. The checksum is placed in byte 511.

11.8.44 Write Log EXT (3Fh)

COMMAND CODE		0 0 1 1 1 1 1 1	REGISTER	
		REGISTER SETTING	NORMAL COMPLETION	
DR		drive no.	no change	
LBA	Current	log address	HOB=0	Reserved
Low	Previous	Reserved	HOB=1	Reserved
LBA	Current	Sector offset(7:0)	HOB=0	Reserved
Mid	Previous	Sector offset(15:8)	HOB=1	Reserved
LBA	Current	Reserved	HOB=0	Reserved
High	Previous	Reserved	HOB=1	Reserved
SC	Current	sector count(7:0)	HOB=0	Reserved
	Previous	sector count(15:8)	HOB=1	Reserved
FT	Current	Reserved	HOB=0	no change
	Previous	Reserved	HOB=1	no change

This command writes a specified number of 512 byte data sectors to the specified log. The device shall interrupt for each DRQ block transferred.

11.8.45 Device Configuration (B1h)

This command has a number of separate functions which can be selected via the Feature Register when the command is issued. The subcommands and their respective codes are listed below.

Subcommand	Feature Register
DEVICE CONFIGURATION RESTORE	C0h
DEVICE CONFIGURATION FREEZE LOCK	C1h
DEVICE CONFIGURATION IDENTIFY	C2h
DEVICE CONFIGURATION SET	C3h

11.8.45.1 Device Configuration Restore

COMMAND CODE	1 0 1 1 0 0 0 1	REGISTER
REGISTER SETTING		NORMAL COMPLETION
DR	DRIVE No.	no change
CY	na	no change
HD	na	no change
SN	na	no change
SC	na	no change
FT	C0h	no change
LBA	na	no change

The DEVICE CONFIGURATION RESTORE command disables any setting previously made by a DEVICE CONFIGURATION SET command and returns the content of the IDENTIFY DEVICE or IDENTIFY PACKET DEVICE command response to the original settings as indicated by the data returned from the execution of a DEVICE CONFIGURATION IDENTIFY command.

11.8.45.2 Device Configuration Freeze Lock

COMMAND CODE	1 0 1 1 0 0 0 1	REGISTER
REGISTER SETTING		NORMAL COMPLETION
DR	DRIVE No.	no change
CY	na	no change
HD	na	no change
SN	na	no change
SC	na	no change
FT	C1h	no change
LBA	na	no change

The DEVICE CONFIGURATION FREEZE LOCK command prevents accidental modification of the Device Configuration Overlay settings. After successful execution of a DEVICE CONFIGURATION FREEZE LOCK command, all DEVICE CONFIGURATION SET, DEVICE CONFIGURATION FREEZE LOCK, DEVICE CONFIGURATION IDENTIFY, and DEVICE CONFIGURATION RESTORE commands are aborted by the device. The DEVICE CONFIGURATION FREEZE LOCK condition shall be cleared by a power-down. The DEVICE CONFIGURATION FREEZE LOCK condition shall not be cleared by hardware or software reset.

11.8.45.3 Device Configuration Identify

COMMAND CODE	1 0 1 1 0 0 0 1	REGISTER
REGISTER SETTING		NORMAL COMPLETION
DR	DRIVE No.	no change
CY	na	no change
HD	na	no change
SN	na	no change
SC	na	no change
FT	C2h	no change
LBA	na	no change

The DEVICE CONFIGURATION IDENTIFY command returns a 512 byte data structure via PIO data-in transfer. The content of this data structure indicates the selectable commands, modes, and feature sets that the device is capable of supporting. If a DEVICE CONFIGURATION SET command has been issued reducing the capabilities, the response to an IDENTIFY DEVICE or IDENTIFY PACKET DEVICE command will reflect the reduced set of capabilities, while the DEVICE CONFIGURATION IDENTIFY command will reflect the entire set of selectable capabilities.

The format of the Device Configuration Overlay data structure is shown in Table 11.8-8.

Table 11.8-8 Device Configuration Identify data structure

Word	Content	
0	Data structure revision	
1	Multiword DMA modes supported	
	15-3	Reserved
	2	1 = Multiword DMA mode 2 and below are supported
	1	1 = Multiword DMA mode 1 and below are supported
	0	1 = Multiword DMA mode 0 is supported
2	Ultra DMA modes supported	
	15-5	Reserved
	5	1 = Ultra DMA mode 5 and below are supported
	4	1 = Ultra DMA mode 4 and below are supported
	3	1 = Ultra DMA mode 3 and below are supported
	2	1 = Ultra DMA mode 2 and below are supported
	1	1 = Ultra DMA mode 1 and below are supported
	0	1 = Ultra DMA mode 0 is supported
3-6	Maximum LBA address	
7	Command set/feature set supported	
	15-9	Reserved
	8	1 = 48-bit Addressing feature set supported
	7	1 = Host Protected Area feature set supported
	6	1 = Automatic acoustic management supported
	5	1 = READ/WRITE DMA QUEUED commands supported
	4	1 = Power-up in Standby feature set supported
	3	1 = Security feature set supported
	2	1 = SMART error log supported
	1	1 = SMART self-test supported
	0	1 = SMART feature set supported
8-254	Reserved	
255	Integrity word	
	15-8	Checksum
	7-0	Signature

11.8.45.3.1.1 Word 0: Data structure revision

Word 0 shall contain the value 0001h.

11.8.45.3.1.2 Word 1: Multiword DMA modes supported

Word 2 bits 2-0 contain the same information as contained in word 63 of the IDENTIFY DEVICE or IDENTIFY PACKET DEVICE command response. Bits 15-3 of word 2 are reserved.

11.8.45.3.1.3 Word 2: Ultra DMA modes supported

Word 3 bits 5-0 contain the same information as contained in word 88 of the IDENTIFY DEVICE or IDENTIFY PACKET DEVICE command response. Bits 15-6 of word 3 are reserved.

11.8.45.3.1.4 Words 3-6: Maximum LBA address

Words 4 through 7 define the maximum LBA address. This is the highest address accepted by the device in the factory default condition. If no DEVICE CONFIGURATION SET command has been executed modifying the factory default condition, this is the same value as that returned by a READ NATIVE MAX ADDRESS or READ NATIVE MAX ADDRESS EXT command.

11.8.45.3.1.5 Word 7: Command/features set supported

Word 7 bit 0 if set to one indicates that the device is capable of supporting the SMART feature set.

Word 7 bit 1 if set to one indicates that the device is capable of supporting SMART self-test including the self-test log.

Word 7 bit 2 if set to one indicates that the device is capable of supporting SMART error logging.

Word 7 bit 3 if set to one indicates that the device is capable of supporting the Security feature set.

Word 7 bit 4 if set to one indicates that the device is capable of supporting the Power-up in Standby feature set.

Word 7 bit 5 if set to one indicates that the device is capable of supporting the READ DMA QUEUED and WRITE DMA QUEUED commands.

Word 7 bit 6 if set to one indicates that the device is capable of supporting the Automatic Acoustic Management feature set.

Word 7 bit 7 if set to one indicates that the device is capable of supporting the Host Protected Area feature set.

Word 7 bit 8 if set to one indicates that the device is capable of supporting the 48-bit Addressing feature set.

Word 7 bits 9 through 15 are reserved.

11.8.45.3.1.6 Words 8-254: Reserved

11.8.45.3.1.7 Word 255: Integrity word

Bits 7:0 of this word shall contain the value A5h. Bits 15:8 of this word shall contain the data structure checksum. The data structure checksum shall be the two's complement of the sum of all byte in words 0 through 254 and the byte consisting of bits 7:0 of word 255. Each byte shall be added with unsigned arithmetic, and overflow shall be ignored. The sum of all bytes is zero when the checksum is correct.

11.8.45.4 Device Configuration Set

COMMAND CODE	1 0 1 1 0 0 0 1	REGISTER
REGISTER SETTING		NORMAL COMPLETION
DR	DRIVE No.	no change
CY	na	no change
HD	na	no change
SN	na	no change
SC	na	no change
FT	C3h	no change
LBA	na	no change

11.8.45.4.1 Error outputs

Register	7	6	5	4	3	2	1	0
Error	na	na	na	na	na	ABRT	na	na
Sector Count	na							
Sector Number	Bit location low							
Cylinder Low	Bit location high							
Cylinder High	Word location							
Device/Head	obs	na	obs	DEV	na			
Status	BSY	DRD Y	DF	na	DRQ	na	na	ERR

Error register -

ABRT shall be set to one if the device does not support this command, if a DEVICE CONFIGURATION SET command has already modified the original settings as reported by a DEVICE CONFIGURATION IDENTIFY command, if DEVICE CONFIGURATION FREEZE LOCK is set, if any of the bit modification restrictions described in this section are violated, or if a Host Protected Area has been established by the execution of a SET MAX ADDRESS command.

Sector Number –

If the command was aborted because an attempt was made to modify a mode or feature that cannot be modified with the device in its current state, this register shall contain bits (7:0) set in the bit positions that correspond to the bits in the device configuration overlay data structure words 1, 2, or 7 for each mode or feature that cannot be changed. If not, the value shall be 00h.

Cylinder Low –

If the command was aborted because an attempt was made to modify a mode or feature that cannot be modified with the device in its current state, this register shall contain bits (15:8) set in the bit positions that correspond to the bits in the device configuration overlay data structure words 1, 2, or 7 for each mode or feature that cannot be changed. If not, the value shall be 00h.

Cylinder High –

If the command was aborted because an attempt was made to modify a bit that cannot be modified with the device in its current state, this register shall contain the offset of the first word encountered that cannot be changed. If an illegal maximum LBA address is encountered, the offset of word 3 shall be entered. If a checksum error occurred, the value FFh shall be entered. A value of 00h indicates that the Data Structure Revision was invalid.

Device register -

DEV shall indicate the selected device.

Status register -

BSY shall be cleared to zero indicating command completion.

DRDY shall be set to one.

DF (Device Fault) shall be set to one if a device fault has occurred.

DRQ shall be cleared to zero.

ERR shall be set to one if an Error register bit is set to one.

11.8.45.4.2 Description

The DEVICE CONFIGURATION SET command allows a device manufacturer or a personal computer system manufacturer to reduce the set of optional commands, modes, or feature sets supported by a device as indicated by a DEVICE CONFIGURATION IDENTIFY command. The DEVICE CONFIGURATION SET command transfers an overlay that modifies some of the bits set in words 63, 82, 83, 84, and 88 of the IDENTIFY DEVICE or IDENTIFY PACKET DEVICE command response. When the bits in these words are cleared, the device shall no longer support the indicated command, mode, or feature set. If a bit is set in the overlay transmitted by the device that is not set in the overlay received from a DEVICE CONFIGURATION IDENTIFY command, no action is taken for that bit. Modifying the maximum LBA address of the device also modifies the address value returned by a READ NATIVE MAX ADDRESS or READ NATIVE MAX ADDRESS EXT command.

The format of the overlay transmitted by the device is described in Table 11.8-9. The restrictions on changing these bits is described in the text following Table 11.8-9. If any of the bit modification restrictions described are violated, the device shall return command aborted.

Table 11.8-9 Device Configuration Overlay data structure

Word	Content	
0	Data structure revision	
1	Multiword DMA modes supported	
	15-3	Reserved
	2	1 = Multiword DMA mode 2 and below are supported
	1	1 = Multiword DMA mode 1 and below are supported
2	Ultra DMA modes supported	
	15-5	Reserved
	5	1 = Ultra DMA mode 5 and below are supported
	4	1 = Ultra DMA mode 4 and below are supported
	3	1 = Ultra DMA mode 3 and below are supported
	2	1 = Ultra DMA mode 2 and below are supported
	1	1 = Ultra DMA mode 1 and below are supported
0	1 = Ultra DMA mode 0 is supported	
3-6	Maximum LBA address	
7	Command set/feature set supported	
	15-9	Reserved
	8	1 = 48-bit Addressing feature set supported
	7	1 = Host Protected Area feature set supported
	6	1 = Automatic acoustic management supported
	5	1 = READ/WRITE DMA QUEUED commands supported
	4	1 = Power-up in Standby feature set supported
	3	1 = Security feature set supported
	2	1 = SMART error log supported
	1	1 = SMART self-test supported
0	1 = SMART feature set supported	
8-254	Reserved	
255	Integrity word	
	15-8	Checksum
	7-0	Signature

11.8.45.4.2.1 Word 0: Data structure revision

Word 0 shall contain the value 0001h.

11.8.45.4.2.2 Word 1: Multiword DMA modes supported

Word 1 bits 15:3 are reserved.

Word 1 bit 2 is cleared to disable support for Multiword DMA mode 2 and has the effect of clearing bit 2 in word 63 of the IDENTIFY DEVICE or IDENTIFY PACKET DEVICE response. This bit shall not be cleared if Multiword DMA mode 2 is currently selected.

Word 1 bit 1 is cleared to disable support for Multiword DMA mode 1 and has the effect of clearing bit 1 in word 63 of the IDENTIFY DEVICE or IDENTIFY PACKET DEVICE response. This bit shall not be cleared if Multiword DMA mode 2 is supported or Multiword DMA mode 1 or 2 is selected.

Word 1 bit 0 shall not be cleared.

11.8.45.4.2.3 Word 2: Ultra DMA modes supported

Word 2 bits 15:6 are reserved.

Word 2 bit 5 is cleared to disable support for Ultra DMA mode 5 and has the effect of clearing bit 5 in word 88 of the IDENTIFY DEVICE or IDENTIFY PACKET DEVICE response. This bit shall not be cleared if Ultra DMA mode 5 is currently selected.

Word 2 bit 4 is cleared to disable support for Ultra DMA mode 4 and has the effect of clearing bit 4 in word 88 of the IDENTIFY DEVICE or IDENTIFY PACKET DEVICE response. This bit shall not be cleared if Ultra DMA mode 5 is supported or if Ultra DMA mode 5 or 4 is selected.

Word 2 bit 3 is cleared to disable support for Ultra DMA mode 3 and has the effect of clearing bit 3 in word 88 of the IDENTIFY DEVICE or IDENTIFY PACKET DEVICE response. This bit shall not be cleared if Ultra DMA mode 5 or 4 is supported or if Ultra DMA mode 5, 4, or 3 is selected.

Word 2 bit 2 is cleared to disable support for Ultra DMA mode 2 and has the effect of clearing bit 2 in word 88 of the IDENTIFY DEVICE or IDENTIFY PACKET DEVICE response. This bit shall not be cleared if Ultra DMA mode 5, 4, or 3 is supported or if Ultra DMA mode 5, 4, 3, or 2 is selected.

Word 2 bit 1 is cleared to disable support for Ultra DMA mode 1 and has the effect of clearing bit 1 in word 88 of the IDENTIFY DEVICE or IDENTIFY PACKET DEVICE response. This bit shall not be cleared if Ultra DMA mode 5, 4, 3, or 2 is supported or if Ultra DMA mode 5, 4, 3, 2, or 1 is selected.

Word 2 bit 0 is cleared to disable support for Ultra DMA mode 0 and has the effect of clearing bit 0 in word 88 of the IDENTIFY DEVICE or IDENTIFY PACKET DEVICE response. This bit shall not be cleared if Ultra DMA mode 5, 4, 3, 2, or 1 is supported or if Ultra DMA mode 5, 4, 3, 2, 1, or 0 is selected.

11.8.45.4.2.4 Words 3-6: Maximum LBA address

Words 3 through 6 define the maximum LBA address. This shall be the highest address accepted by the device after execution of the command. When this value is changed, the content of IDENTIFY DEVICE words 60, 61, 100, 101, 102, and 103 shall be changed as described in the SET MAX ADDRESS and SET MAX ADDRESS EXT command descriptions to reflect the maximum address set with this command. This value shall not be changed and command aborted shall be returned if a Host Protected Area has been established by the execution of a SET MAX ADDRESS or SET MAX ADDRESS EXT command with an address value less than that returned by a READ NATIVE MAX ADDRESS or READ NATIVE MAX ADDRESS EXT command. Any data contained in the Host Protected Area is not affected.

11.8.45.4.2.5 Word 7: Command/features set supported

Word 7 bits 15:9 are reserved.

Word 7 bit 8 is cleared to disable support for the 48-bit Addressing feature set and has the effect of clearing bit 10 in words 83 and 86 and clearing the value in words 103:100 of the IDENTIFY DEVICE or IDENTIFY PACKET DEVICE response.

Word 7 bit 7 is cleared to disable support for the Host Protected Area feature set and has the effect of clearing bit 10 in words 82 and 85 and clearing bit 8 in words 83 and 86 of the IDENTIFY DEVICE or IDENTIFY PACKET DEVICE response. If a Host Protected Area has been established by use of the SET MAX ADDRESS command, these bits shall not be cleared and the device shall return command aborted.

Word 7 bit 6 is cleared to disable for the Automatic Acoustic Management feature set and has the effect of clearing bit 9 in word 83 and word 94 of the IDENTIFY DEVICE or IDENTIFY PACKET DEVICE response.

Word 7 bit 5 is cleared to disable support for the READ DMA QUEUED and WRITE DMA QUEUED commands and has the effect of clearing bit 1 in words 83 and 86 of the IDENTIFY DEVICE or IDENTIFY PACKET DEVICE response.

Word 7 bit 4 is cleared to disable support for the Power-up in Standby feature set and has the effect of clearing bits 5 and 6 in words 83 and 86 and clearing the value in word 94 of the IDENTIFY DEVICE or IDENTIFY PACKET DEVICE response. If Power-up in Standby has been enabled by a jumper, these bits shall not be cleared.

Word 7 bit 3 is cleared to disable support for the Security feature set and has the effect of clearing bit 1 in words 82 and 85 of the IDENTIFY DEVICE or IDENTIFY PACKET DEVICE response. These bits shall not be cleared if the Security feature set has been enabled.

Word 7 bit 2 is cleared to disable support for the SMART error logging and has the effect of clearing bit 0 in words 84 and 87 of the IDENTIFY DEVICE or IDENTIFY PACKET DEVICE response.

Word 7 bit 1 is cleared to disable support for the SMART self-test and has the effect of clearing bit 1 in words 84 and 87 of the IDENTIFY DEVICE or IDENTIFY PACKET DEVICE response.

Word 7 bit 0 is cleared to disable support for the SMART feature set and has the effect of clearing bit 0 in words 82 and 85 of the IDENTIFY DEVICE or IDENTIFY PACKET DEVICE response. If bits 1 and 2 of word 7 are not cleared to zero or if the SMART feature set has been enabled by use of the SMART ENABLE OPERATIONS command, these bits shall not be cleared and the device shall return command aborted.

11.8.45.4.2.6 Words 8-254: Reserved

11.8.45.4.2.7 Word 255: Integrity word

Bits 7:0 of this word shall contain the value A5h. Bits 15:8 of this word shall contain the data structure checksum. The data structure checksum shall be the two's complement of the sum of all byte in words 0 through 254 and the byte consisting of bits 7:0 of word 255. Each byte shall be added with unsigned arithmetic, and overflow shall be ignored. The sum of all bytes is zero when the checksum is correct.

11.9 Security Mode Feature Set

The Security mode features allow the host to implement a security password system to prevent unauthorized access to the disk drive.

- Following Commands are supported for this feature set .
- SECURITY SET PASSWORD
- SECURITY UNLOCK
- SECURITY ERASE PREPARE
- SECURITY ERASE UNIT
- SECURITY FREEZE LOCK
- SECURITY DISABLE PASSWORD

Parameter word for the Security mode feature set is described in IDENTIFY DEVICE response Word 128.

11.9.1 Security mode default setting

The drive is shipped with the master password set to 20h value (ASCII blanks) and the lock function disabled. The system manufacturer/dealer may set a new master password by using the SECURITY SET PASSWORD command, without enabling the lock function.

If the Master Password Revision Code feature is supported, the Master Password Revision Code is initially set to FFFEh.

11.9.2 Initial setting of the user password

When a user password is set, the drive automatically enters lock mode by the next powered-on .

11.9.3 Security mode operation from power-on

In locked mode, the drive rejects media access commands until a SECURITY UNLOCK command is successfully completed.

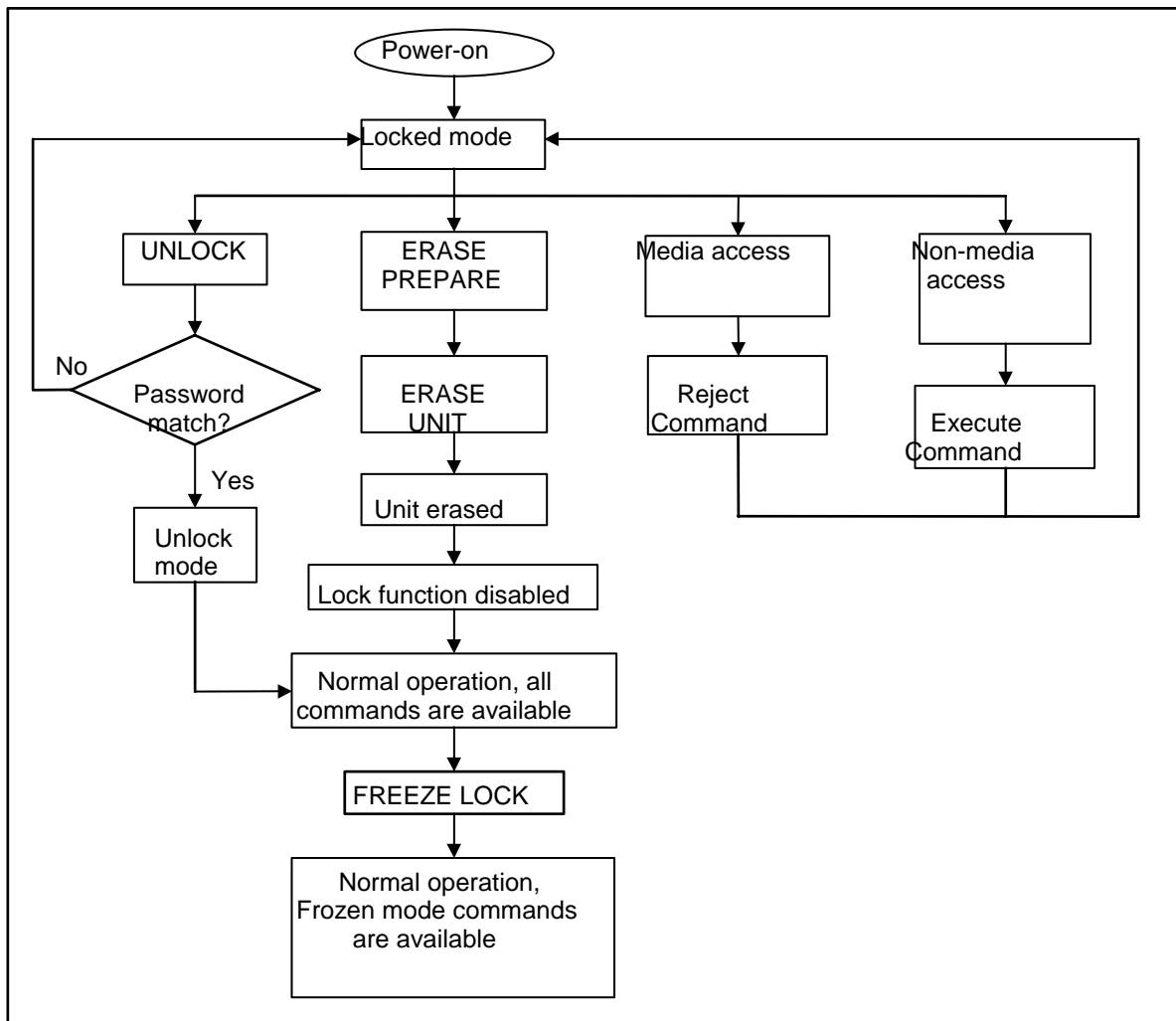

Figure 4 Password set security mode power-on flow

11.9.4 Password lost

If the user password is lost and High level security is set, the drive does not allow the user to access any data. However, the drive can be unlocked using the master password.

If the user password is lost and Maximum security level is set, it is impossible to access data. However, the drive can be unlocked using the ERASE UNIT command with the master password. The drive will erase all user data and unlock the drive.

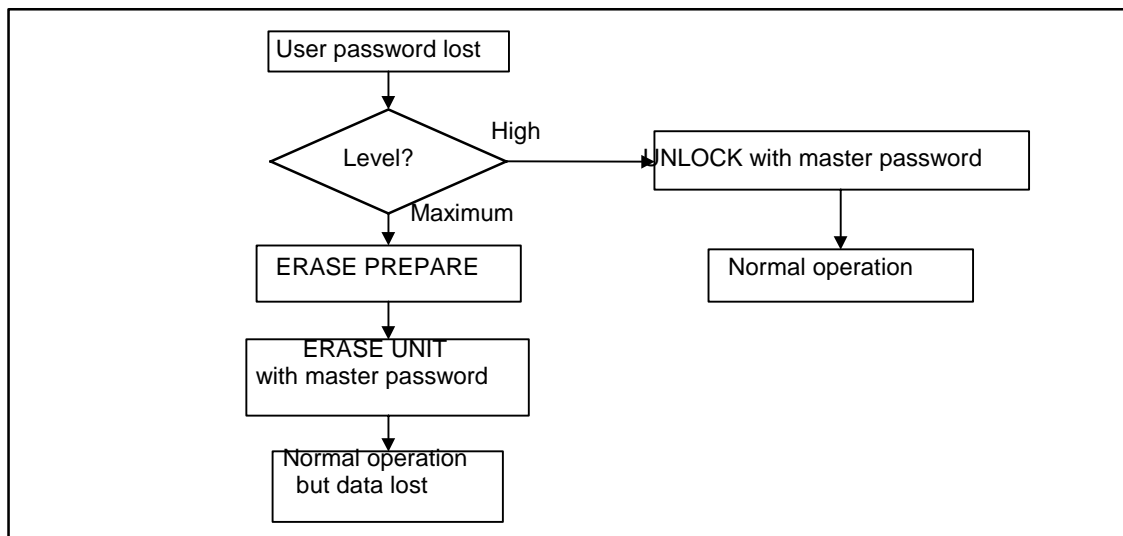

Figure 5 User password lost

If both the user password and the master password are lost, the drive cannot be in normal operation mode.

11.9.5 Command Table

This command table shows the drive's response to commands when the Security Function is enabled.

Table 11.9-1 Security mode command actions

Command	Locked mode	Unlocked mode	Frozen mode
CHECK POWER MODE	O	O	O
EXECUTE DEVICE DIAGNOSTICS	O	O	O
DEVICE CONFIGURATION	X	O	O
DOWNLOAD MICROCODE	O	O	O
FLUSH CACHE (EXT)	X	O	O
FORMAT TRACK	X	O	O
IDENTIFY DEVICE	O	O	O
IDLE	O	O	O
IDLE IMMEDIATE	O	O	O
INITIALIZE DEVICE PARAMETERS	O	O	O
NOP	O	O	O
READ BUFFER	O	O	O
READ DMA (EXT)	X	O	O
READ MULTIPLE (EXT)	X	O	O
READ NATIVE MAX ADDRESS (EXT)	O	O	O
READ SECTORS (EXT)	X	O	O
READ SENSE DATA	O	O	O
READ VERIFY (EXT)	X	O	O
RECALIBRATE	O	O	O
SECURITY DISABLE PASSWORD	X	O	X
SECURITY ERASE PREPARE	O	O	O
SECURITY ERASE UNIT	O	O	X
SECURITY FREEZE LOCK	X	O	O
SECURITY SET PASSWORD	X	O	X
SECURITY UNLOCK	O	O	X
SEEK	O	O	O
SET FEATURES	O	O	O
SET MAX (EXT)	X	O	O
SET MULTIPLE MODE	O	O	O
SLEEP	O	O	O
SMART	O	O	O
STANDBY	O	O	O
STANDBY IMMEDIATE	O	O	O
WRITE BUFFER	O	O	O
WRITE DMA (EXT)	X	O	O
WRITE MULTIPLE (EXT)	X	O	O
WRITE SECTORS (EXT)	X	O	O
WRITE VERIFY	X	O	O

O: Drive executes command normally

X: Drive rejects command with an Aborted command error

11.10 Self-Monitoring, Analysis and Reporting Technology

Self-monitoring, analysis and reporting technology (SMART) is the function to protect user data and to minimize the likelihood of unscheduled system downtime that may be caused by predictable degradation and/or fault of the drive. By monitoring and storing the critical performance and calibration parameters, SMART drives attempt to predict the likelihood of near-term degradation or fault condition. The host system warns the user of the impending risk of data loss and advises the user of appropriate action by informing the host system of the negative reliability .

SMART commands use a single command code and are differentiated by the value placed in the Features register.

The Commands supported by this feature set are:

- SMART READ ATTRIBUTE VALUES
- SMART READ ATTRIBUTE THRESHOLDS
- SMART ENABLE/DISABLE ATTRIBUTE AUTOSAVE
- SMART SAVE ATTRIBUTE VALUE
- SMART EXECUTE OFF-LINE IMMEDIATE
- SMART READ LOG SECTOR
- SMART WRITE LOG SECTOR
- SMART ENABLE OPERATIONS
- SMART DISABLE OPERATIONS
- SMART RETURN STATUS
- SMART ENABLE/DISABLE AUTOMATIC OFF-LINE

11.10.1 Attributes

Attributes are the specific performance or calibration parameters that are used in analyzing the status of the drive. Attributes are selected by the drive manufacturer based on that attribute's ability to predict degrading or faulty conditions for that particular drive. The specific set of attribute being used and the identity of these attributes is vendor specific and proprietary.

11.10.2 Attributes values

Attribute values are used to measure the relative reliability of individual performance or calibration attributes.

11.10.3 SMART function default setting

The drives are shipped from the drive manufacturer's factory with the SMART feature disabled. SMART feature will be enabled by the system manufacturer or the application.

11.11 Adaptive Power Mode Control

Adaptive Power Mode Control is a function to reduce power consumption without performance degradation. The drive supports the following Idle modes of 3 levels. The drive enters into idle mode adaptively in accordance with the command pattern.

11.11.1 Performance Idle

The drive enters Performance Idle mode at the completion of a command from host. In this mode, electric circuit and servo is ready to process the next command without delay.

11.11.2 Active Idle

Some of electric circuit and servo functions are powered off in this mode. The heads are stopped near the disk center. If a shock is detected by Shock Sensor, the drive enters into Performance Idle mode automatically. Power consumption for Active Idle mode is 55% ~ 65% lower than that of Performance Idle mode. Command processing time is approximately 35ms longer than that of Performance Idle mode.

11.11.3 Low Power Idle

In Low Power Idle mode, the heads are unloaded on the ramp and the spindle motor continues normal rotation. Power consumption for Low Power Idle mode is 60% ~ 70% lower than that of Performance Idle mode. Command processing time is approximately 400ms longer than that of Performance Idle mode.

11.11.4 Transition time

The transition time changes dynamically in accordance with the current command pattern.

11.12 Reset

A RESET condition sets the drive (or both drives in case of Drive0/Drive1 connection) BSY, allowing the drive to perform the specified initialization required for normal operation.

A RESET condition can be generated by both hardware and software. There are two hardware resets, one is by the Host (- RESET) and the other is by the drive power sense circuitry. These resets are set high when the system and the drive respectively acknowledge specified supply voltage (See 6.1).

The other reset is software generated. The Host can write to the Device Control register and set the reset bit. The host software condition will continue until the reset bit is set to zero.

Once the reset is negated and the drive is re-enabled, with BSY still active, the drive will perform necessary hardware initialization, clear any previously programmed drive parameters and revert to the defaults, load the Task File registers with their initial values, and then clear BSY. No interrupt is generated when initialization is complete. The initial values (hex) for the Task File registers are as follows.

Table 11.12-1 Initialization of Task File registers

REGISTER	POWER ON	HARDWARE RESET	SOFTWARE RESET
Data	00	00	00
Error	01	01	01
Sector Count	01	01	01
Sector Number	01	01	01
Cylinder Low	00	00	00
Cylinder High	00	00	00
Device/Head Register	00	00	00
Status/Alternate Status	50 or 52	50 or 52	50 or 52
Device address ⁹	7E or FE	7E or FE	7E or FE
ECC Length	4 bytes	4 bytes	no change(*1)
Data Buffer	undefined	undefined	no change
Addressing mode	default	default	no change
Auto stand-by mode	disable	disable	no change
Read Cache	enable	enable	no change (*1)
Write Cache ¹⁰	enable	enable	no change (*1)
Multiple mode	16 sectors	16 sectors	no change (*1)
DMA transfer mode	Multiword DMA mode 2	Multiword DMA mode 2	no change(*1)
PIO transfer mode	PIO mode 4 flow control	PIO mode 4 flow control	no change(*1)

(*1): Software reset settings are affected by set feature command.

⁹ ATA-2 Notes: This register is obsolete. It is recommended that a device not respond to a read of this address. If a device does respond, it shall be sure not to drive the DD7 signal to prevent possible conflict with floppy disk implementations.

The drive supports this register to maintain compatibility for ATA-1.

¹⁰ ATA-2 Notes: The default mode for write cache is “disable” after ATA-2. This is violation of ATA-2 specification. This setting can be changed by factory.

11.13 Drive0/Drive1 Configuration

Drive address shall be set by the optional jumper of interface connector.

The drive runs as Drive0 when the jumper is open or if jumper plug is set to position B-D when P28(CSEL) signal is low. The drive runs as Drive1 when the jumper plug is inserted into position C-D or if jumper plug is set to position B-D when P28 (CSEL) signal is high. In case of two- drive configuration, one shall be Drive0 and the other should be Drive1.

ATA /ATAPI specifies to use P28 with jumper plug set to position B-D. It is recommended to follow the ATA / ATAPI specification.

Jumper	P28	Drive
No Jumper	-	Drive0
C-D Jumper	-	Drive1
B-D Jumper	LOW	Drive0
B-D Jumper	HIGH	Drive1
A-B Jumper	-	Drive1
A-C Jumper	-	Prohibit

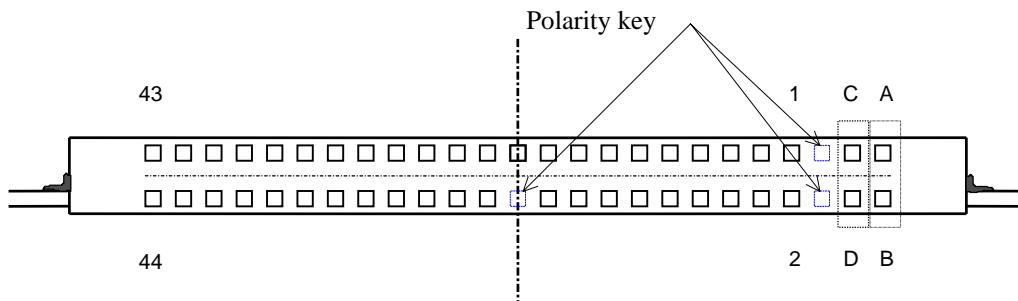

Figure 6 Optional jumper for Drive0/Drive1

11.14 Cache Memory

11.14.1 Cache Operations

(1) READ CACHE OPERATION

Receiving a read command, the data in the buffer memory are sent to the host without access to the disk media as long as the object data reside in the buffer memory and the conditions for the drive's read cache operation are fulfilled.

If any of the conditions of the read cache operation is not fulfilled, the drive carries out read data operation and the object data for the read command is read from the media and kept in the buffer and then the data is transferred from the buffer to the host.

The following data required by the read command may continuously be read by the buffer under the drive's read ahead cache operation until the buffer available for read cache is full or the new command is received.

(2) WRITE CACHE OPERATION

Receiving a write command, the drive continuously receives the write data from the host until all data are transferred or the buffer available for write cache is full, whether the data are written on the media or not. If all data for the command are received, the drive reports completion of the command by negating BSY bit and issuing INTERRUPT.

If the command which follows the write cache command is also a write command for succeeding block address, the drive receives write data from host without waiting for the previously received data to be written on the media. And the drive reports completion of the command when the buffer receives all the data.

During a write cache operation, DASP (LED) signal line is kept "on" until all the data in the write buffer are written on the media.

11.14.2 Notes for write cache

(1) Loss of data in write buffer

If write cache is enabled, hard reset or soft reset does not cause data loss. But power off immediate after completion of the command may cause data loss, because actual writing of the data onto the media is not completed at this moment. Therefore, it is recommended that any other command except write or read command is executed and completion of the command is confirmed before powering off the drive. Stand-by command can be helpful for this purpose.

(2) Error report

When write cache is enabled, any unrecoverable error encountered after the report of completion of a command shall be reported by the later command. Actual writing of the data onto the media may not be completed at this moment. In this case, READY bit is negated to show that the error has occurred during the write cache operation previously executed.

Address validity check is performed with actual media access. The error may be reported during the execution of a command or after completion of a write cache command if the address the data has tried to access is non-existent.

11.15 Automatic Write Reallocation

If the drive has difficulty in executing normal write operation due to unrecoverable errors such as ID NOT FOUND, the sectors those show some errors may be reallocated automatically to continue normal operation and secure the write data. This operation is helpful especially in write cache, when the completion of the command is reported before actual writing to media. During write operation including this AWRE function, DASP signal is kept " on ". This operation takes 20 seconds maximum to be completed, therefore, the time-out period should be set longer than this value. If the next command is a write command, the data of the first block will be transferred without any delay.

12. Protocol

Commands can be grouped into different classes according to the protocols used for command execution. The command classes with their associated protocols are defined below.

For all commands, the host first checks BSY bit and DRDY bit. If BSY = 1, the host should proceed no further unless and until the BSY = 0, and the DRDY = 1.

Interrupts are cleared when host reads Status register, issues a reset, or writes to the Command register. Interrupts are not cleared when host reads Alternate Status register.

A command shall only be interrupted with a hardware or software reset. The result of writing to the command register while BSY = 1 or DRQ = 1 is unpredictable and may result in data corruption. Therefore, a command should only be interrupted by a reset at times when the host judges that there is a problem, such as receiving no response from a drive. Host programmers should set command time-out periods enough long in order to avoid having effect on the device's ability to perform level retry and data recovery activities.

12.1 PIO data in commands

Commands for this class are:

- IDENTIFY DEVICE
- READ BUFFER
- READ SECTOR(S) (with and without retry)
- READ SECTOR(S) EXT
- READ MULTIPLE
- READ MULTIPLE EXT
- SMART Read Attribute Values
- SMART Read Attribute Thresholds
- SMART Read Log Sector
- DEVICE CONFIGURATION IDENTIFY

PIO data in protocol:

- a) The host writes any required command parameters to the Features, Sector Count, Sector Number, Cylinder High, Cylinder Low and Device/Head registers.
- b) The host writes the command code to the Command register.
- c) For each sector (or block) of data to be transferred:
 - 1) The drive sets BSY bit and prepares to transfer a sector (or block) of data to the host.
 - 2) When a sector (or block) of data is available for transfer to the host, the drive sets the DRQ bit and clears the BSY bit and asserts INTRQ.
 - 3) After detecting INTRQ, the host reads the contents of the Status register.
 - 4) The drive negates INTRQ in response to the Status register being read.
 - 5) The host reads a sector (or block) of data via the Data register.
 - 6) In response to a sector (or block) of data being transferred, the drive clears the DRQ bit.

The Read Multiple command transfers one block (the number of sectors defined by the Set Multiple command) of data for each interrupt. The other commands transfer one sector of data for each interrupt.

If the drive detects an invalid parameter in register setting, the drive clears BSY bit and sets the ERR bit in the Status register and sets ABRT bit in the Error register and asserts INTRQ in order to terminate the command execution.

If an uncorrectable error occurs, the drive will set DRQ bit and clear BSY bit and set ERR bit and stores the error status in Error register and address the information of the error sector to Sector Number, Cylinder High, Cylinder Low and Device/Head registers and asserts INTRQ.

If uncorrectable data error (the UNC is set) occurs, the drive will transfer a sector of the defective data to the host. If the others error occur, the contents of the data to be transferred shall not be ensured. In both cases, the host should complete transfer of the sector of data in response to INTRQ being asserted. In case of Read Multiple command, the host should complete transfer of a block of data which includes the sector with defective data.

12.2 PIO data out commands

Commands for this class are:

- (FORMAT TRACK)
- WRITE BUFFER

- WRITE MULTIPLE
- WRITE MULTIPLE EXT
- WRITE SECTOR(S) (with and without retry)
- WRITE SECTOR(S) EXT
- WRITE VERIFY
- SECURITY DISABLE PASSWORD
- SECURITY ERASE UNIT
- SECURITY SET PASSWORD
- SECURITY UNLOCK
- SET MAX SET PASSWORD
- SMART Write Log Sector
- DOWNLOAD MICROCODE

PIO data out protocol:

- a) The host writes any required command parameters to the Features, Sector Count, Sector Number, Cylinder High, Cylinder Low and Device/Head registers.
- b) The host writes the command code to the Command register.
- c) The drive sets the BSY bit .
- d) For each sector (or block) of data to be transferred:
 - 1) When the drive is ready to receive a sector (or block) of data from the host, it sets the DRQ bit and clears the BSY bit.
 - 2) The host writes a sector (or block) of data via the Data Register.
 - 3) After receiving the sector (or block) , the drive clears the DRQ bit and sets the BSY bit.
 - 4) When the drive has finished processing the sector (or block) , it sets the DRQ bit and clears the BSY bit and asserts INTRQ.
 - 5) After detecting INTRQ, the host reads the Status register.
 - 6) The drive negates INTRQ in response to the Status register being read.

The drive negates INTRQ in response to the Status register being read.

The Write Multiple command transfers one block (the number of sectors is defined by the Set Multiple command) of data for each interrupt. The other commands transfer one sector of data for each interrupt.

If the drive detects an invalid parameter in register setting, the drive clears the BSY bit and sets the ERR bit in the Status register and sets the ABRT bit in the Error register and asserts INTRQ to terminate the command execution.

If an unrecoverable error occurs, the drive sets the DRQ bit and clears the BSY bit and sets the ERR bit and stores the error status in Error register and report the address information of the sector with error to Sector Number, Cylinder High, Cylinder Low and Device/Head registers and asserts INTRQ.

12.3 Non-data commands

Commands for this class are:

- CHECK POWER MODE
- EXECUTE DEVICE DIAGNOSTICS
- FLUSH CACHE
- FLUSH CACHE EXT
- IDLE
- IDLE IMMEDIATE
- INITIALIZE DEVICE PARAMETERS
- NOP
- READ VERIFY SECTOR(S)
- READ VERIFY SECTOR(S) EXT
- READ NATIVE MAX ADDRESS
- READ NATIVE MAX ADDRESS EXT
- RECALIBRATE
- SEEK
- SET FEATURES
- SET MULTIPLE MODE
- SLEEP
- STANDBY
- STANDBY IMMEDIATE
- SECURITY ERASE PREPARE
- SECURITY FREEZE LOCK
- SMART Enable/Disable Attribute Autosave
- SMART Save Attribute Values
- SMART Executive Off-line Immediate
- SMART Enable Operation
- SMART Disable Operation
- SMART Return Status
- SMART Enable/Disable Automatic Off-line
- SET MAX ADDRESS
- SET MAX ADDRESS EXT
- SET MAX LOCK
- SET MAX UNLOCK
- SET MAX FREEZE LOCK
- DEVICE CONFIGURATION RESTORE
- DEVICE CONFIGURATION FREEZE LOCK
- DEVICE CONFIGURATION SET
- READ SENCE DATA

Non-data protocol:

- a) The host writes any required command parameters to the Features, Sector Count, Sector Number, Cylinder High, Cylinder Low and Device/Head registers.

- b) The host writes the command code to the Command register.
- c) The drive sets the BSY bit .
- d) When the drive has finished processing a sector (or block) of data, it clears the BSY bit and asserts INTRQ.
- e) In response to the INTRQ, the host reads the Status register.
- f) The drive negates INTRQ in response to the Status register being read

See each command description for error report protocol.

12.4 DMA data transfer commands

Commands for this class are:

- READ DMA (with and without retry)
- READ DMA EXT
- WRITE DMA (with and without retry)
- WRITE DMA EXT

Data transfers using DMA commands differ in two ways from PIO transfers:

data transfers are performed using the DMA channel

the drive issues only one interrupt at the completion of each command

Initiation of the DMA transfer commands is identical to the READ SECTOR(S) or WRITE SECTOR(S) commands except that the host initializes the DMA channel prior to issuing the command.

The interrupt handler for DMA transfers is different in that no intermediate sector interrupts are issued on multi-sector transfer but issued only once at the completion of each command.

DMA data transfer protocol:

- a) Host initializes the DMA channel.
- b) Host writes any required command parameters to the Features, Sector Count, Sector Number, Cylinder High, Cylinder Low and Device/Head registers.
- c) Host writes the command code to the Command register.
- d) The drive sets the BSY bit .
- e) The drive sets DMARQ, when it is ready to transfer data.
- f) Host transfers the data using DMA transfer mode set by the Set Features command .
- g) When all of the data has been transferred, the drive issues INTRQ.
- h) The host resets the DMA channel.
- i) After detecting INTRQ, the host reads the Status register.
- j) The drive negates INTRQ in response to the Status register being read.

12.5 Ultra DMA

Ultra DMA protocol is used with Read DMA, and Write DMA commands. Ultra DMA modes are set by Set Features command. Since the setting after power-up (Default setting) is mode 2 of Multi Word DMA, Set Features command shall be issued to be used in Ultra DMA mode.

An Ultra DMA data transfer is accomplished through a series of Ultra DMA data in or data out bursts. Each Ultra DMA burst has three mandatory phases of operation: the initiation phase, the data transfer phase, and the Ultra DMA burst termination phase. An Ultra DMA burst is defined as the period from an assertion of DMACK- by the host to the subsequent negation of DMACK-. A recipient shall be prepared to receive at least 2 data words.

Both the host and drive perform a CRC function during an Ultra DMA burst. At the end of an Ultra DMA burst, the drive compares its CRC data to the data sent from the host. The drive requires an Ultra DMA burst termination for each sector to compare CRC data to the data sent from the host.

1. Initiation phase

- a) An Ultra DMA burst initiation phase begins with the assertion of DMARQ by the drive and ends when the sender generates a STROBE edge to transfer the first data word.
- b) An Ultra DMA burst is always requested by a drive asserting DMARQ.
- c) A host indicates it is ready to initiate the requested Ultra DMA burst by asserting DMACK-.
- d) A host shall never assert DMACK- without first detecting that DMARQ is asserted.
- e) For Ultra DMA data in bursts: a drive may begin driving DD(15:0) after detecting that DMACK- is asserted, STOP negated, and HDMARDY- is asserted.
- f) After asserting DMARQ or asserting DDMARDY- for an Ultra DMA data out burst, the shall not negate either signal until the first STROBE edge is generated.
- g) After negating STOP or asserting HDMARDY- for an Ultra DMA data in burst, a host shall not change the state of either signal until the first STROBE edge is generated.

2. Data transfer phase

- a) The data transfer phase is in effect from after Ultra DMA burst initiation until Ultra DMA burst termination.
- b) A recipient pauses an Ultra DMA burst by negating DMRDY- and resumes an Ultra DMA burst by reasserting DMARDY-.
- c) A sender pauses an Ultra DMA burst by not generating STROBE edges and resumes by generating STROBE edges.
- d) A recipient must not signal a termination request when a sender stops generating STROBE edges. In the absence of a termination from the sender, the recipient should always negate DMARDY- and wait the required period before signaling a termination request.
- e) A sender may generate STROBE edges at greater than the minimum period specified by the enabled Ultra DMA Mode . The sender should not generate STROBE edges at less than the minimum period specified by the abled Ultra DMA Mode. A recipient should be able to receive data at the minimum period specified by the enabled Ultra DMA Mode.

3. Ultra DMA burst termination phase

- a) Either a sender or a recipient may terminate an Ultra DMA burst.
- b) Ultra DMA burst termination is not the same as command termination or completion. If an Ultra DMA burst termination occurs before the command is complete, the command shall be completed by initiation of a new Ultra DMA burst at some later time or aborted by the host issuing a hardware or software reset to the drive.
- c) An Ultra DMA shall be paused before a recipient requests a termination.
- d) A host requests a termination by asserting STOP. A drive acknowledges a termination request by negating DMARQ.
- e) A drive requests a termination by negating DMARQ. A host acknowledges a termination request by asserting STOP.
- f) Once a sender requests a termination, it does not change the state of STROBE until the recipient acknowledges the request. Then, if STROBE is not the asserted state, the sender returns STROBE to the asserted state. No data shall be transferred on this transition of STROBE.
- g) A sender returns STROBE to the asserted state whenever it detects a termination request from the recipient. No data shall be transferred nor CRC calculated on this edge of DSTROBE.
- h) Once a recipient requests a termination, it does not change DMARDY from the negated state for the remainder of an Ultra DMA burst.
- k) A recipient ignores a STROBE edge when DMARQ is negated or STOP is asserted.

CRC

Both the host and drive perform a CRC function during an Ultra DMA burst. The host and drive use 4ABAh as an initial value. The host and the drive calculate CRC value during each STROBE edge of data transfer using current value of CRC and transferred data with CRC polynomial. CRC function is not performed after an Ultra DMA burst completion of STROBE set. At the completion of an Ultra DMA burst, the host reports the CRC data on data bus and negates DMACK- to pass the result to the drive.

The drive compares the CRC data sent from the host. If the two values do not match, the drive reports an error after at the end of the command. The generative polynomial for CRC is :

$$(X) = X^{16} + X^{12} + X^5 + 1$$

The following figure shows an example of CRC generative logic (ATA / ATAPI-6)

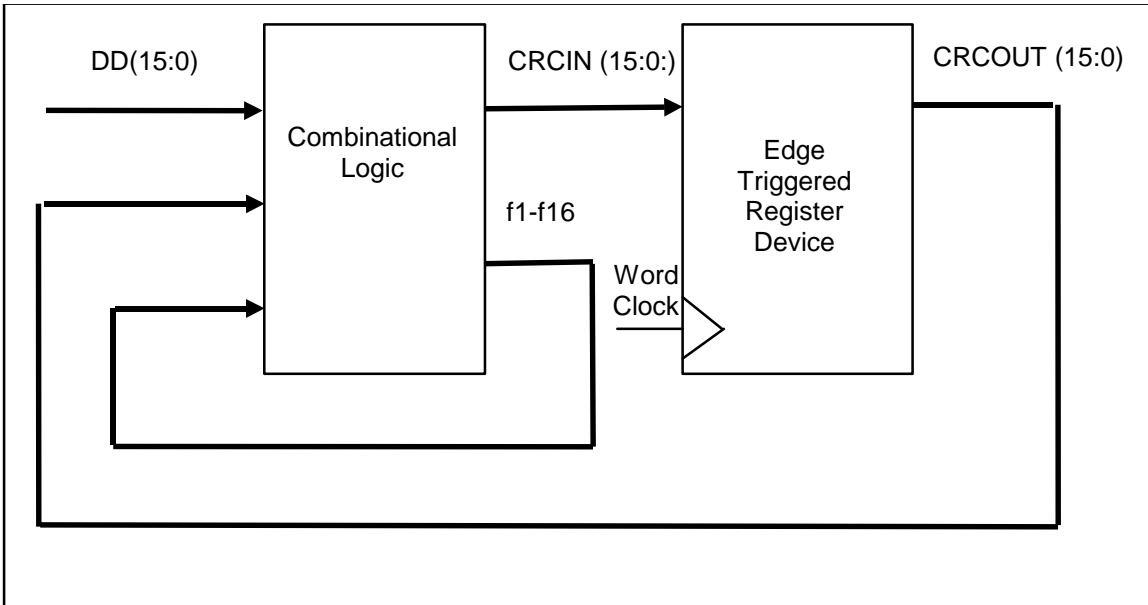

$CRCIN0 = f16$	$CRCIN8 = f8 \text{ XOR } f13$
$CRCIN1 = f15$	$CRCIN9 = f7 \text{ XOR } f12$
$CRCIN2 = f14$	$CRCIN10 = f6 \text{ XOR } f11$
$CRCIN3 = f13$	$CRCIN11 = f5 \text{ XOR } f10$
$CRCIN4 = f12$	$CRCIN12 = f4 \text{ XOR } f9 \text{ XOR } f16$
$CRCIN5 = f11 \text{ XOR } f16$	$CRCIN13 = f3 \text{ XOR } f8 \text{ XOR } f15$
$CRCIN6 = f10 \text{ XOR } f15$	$CRCIN14 = f2 \text{ XOR } f7 \text{ XOR } f14$
$CRCIN7 = f9 \text{ XOR } f14$	$CRCIN15 = f1 \text{ XOR } f6 \text{ XOR } f13$
$f1 = DD0 \text{ XOR } CRCOUT15$	
$f2 = DD1 \text{ XOR } CRCOUT14$	
$f3 = DD2 \text{ XOR } CRCOUT13$	
$f4 = DD3 \text{ XOR } CRCOUT12$	
$f5 = DD4 \text{ XOR } CRCOUT11 \text{ XOR } f1$	
$f6 = DD5 \text{ XOR } CRCOUT10 \text{ XOR } f2$	
$f7 = DD6 \text{ XOR } CRCOUT9 \text{ XOR } f3$	
$f8 = DD7 \text{ XOR } CRCOUT8 \text{ XOR } f4$	
$f9 = DD8 \text{ XOR } CRCOUT7 \text{ XOR } f5$	
$f10 = DD9 \text{ XOR } CRCOUT6 \text{ XOR } f6$	
$f11 = DD10 \text{ XOR } CRCOUT5 \text{ XOR } f7$	
$f12 = DD11 \text{ XOR } CRCOUT4 \text{ XOR } f1 \text{ XOR } f8$	
$f13 = DD12 \text{ XOR } CRCOUT3 \text{ XOR } f2 \text{ XOR } f9$	
$f14 = DD13 \text{ XOR } CRCOUT2 \text{ XOR } f3 \text{ XOR } f10$	
$f15 = DD14 \text{ XOR } CRCOUT1 \text{ XOR } f4 \text{ XOR } f11$	
$f16 = DD15 \text{ XOR } CRCOUT0 \text{ XOR } f5 \text{ XOR } f12$	
Notes:	
1) f = feedback	
2) DD = Data to or from the bus	
3) CRCOUT = 16-bit edge triggered result (current CRC)	
4) CRCOUT(15:0) are sent on matching order bits of DD(15:0)	
5) CRCIN = Output of combinatorial logic (next CRC)	

12.6 Other timings

See HOST INTERFACE section for timings which are not shown here.

Table 12.6-1 Other timings.

Function and Intervals	Timeout	
• POWER ON TIMINGS		
From power on to BSY=1	400 ns	maximum
From Power on to BSY=0, DRDY=1	31 s	maximum
• SOFT RESET TIMINGS		
From soft reset assertion (SRST=1) to BSY=1	400 ns	maximum
From soft reset negation (SRST=0) to drive ready (BSY=0, DRDY=1)	10 sec	maximum
• HARD RESET TIMINGS		
From hard reset assertion to BSY=1	400 ns	maximum
From hard reset negation to drive ready (BSY=0, DRDY=1)	31 sec	maximum
• DATA IN COMMANDS		
From writing to command register to BSY=1	400 ns	maximum
From BSY=1 to BSY=0, DRQ=1, INTRQ set (When the drive is in idle mode)	20 sec	maximum
From BSY=1 to BSY=0, DRQ=1, INTRQ set (When the drive is in standby mode)	35 sec	maximum
Drive Busy during data transfer	5 μ s	minimum
• DATA OUT COMMANDS		
From writing to command register to BSY=1	400 ns	maximum
From BSY=1 to BSY=0, DRQ=1	700 μ s ^(*1)	maximum
Drive Busy during data transfer	5 μ s	minimum
From BSY=1 to INTRQ set (When the drive is in idle mode)	10 sec	maximum
From BSY=1 to INTRQ set (When the drive is in standby mode)	25 sec	maximum
• NON-DATA COMMANDS		
From writing to command register to BSY=1	400 ns	maximum
From BSY=1 to INTRQ set (When the drive is in standby mode)	17 sec	maximum
• DMA DATA TRANSFER COMMANDS		
From writing to command register to BSY=1	400 ns	maximum

(*1) When the following commands are issued by the host as First Command after hardware reset, the command's time-out value of the field is 10 seconds.

- Security Diable Password
- Security Erase Unit
- Security Set Password
- Security Unlock